

stage



Setting up your
KC-Z1 Controller



KENWOOD

Licensing

Manufactured under license from Dolby Laboratories Licensing Corporation.

'Dolby', 'Pro Logic', 'AC-3', and the  symbol are trademarks of Dolby Laboratories Licensing Corporation.

Manufactured under license from Lucasfilm Ltd. US patents 5,043,970; 5,189,703; and 5,222,059. Foreign patents pending. 'THX' is a registered trademark, and 'Re-Equalization', 'Decorrelation', and 'Timbre Matching' are trademarks of Lucasfilm Ltd.

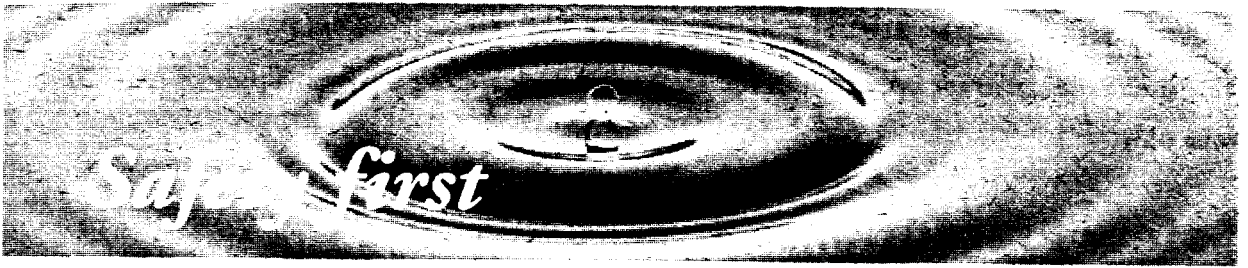

WARNING

To prevent fire or electric shock, do not expose this unit to rain or moisture.

CAUTION

To prevent electric shock, match the wide blade of the plug to the wide slot in a wall socket, and insert fully.



CAUTION

To reduce the risk of electric shock, do not remove the unit's cover. There are no user-servicable parts inside. Have the unit serviced by qualified service personnel.

Safety Symbols

We've placed these safety symbols on the back of the unit.



The lightning bolt symbol is to alert you to the danger of electric shock from the operating electric parts inside the unit.



The exclamation point symbol is to let you know that there are important operating and servicing instructions in this manual that you should read before you operate this unit.

About the power supply

This unit is designed for operation in the USA and Canada using a power supply of AC 120 volts only.

Safety Precautions

Read this page carefully to ensure safe operation. Please read all of the safety and operating instructions before operating this unit. Adhere to all warnings on the unit and in this manual. Follow all the safety and operating instructions. These safety and operating instructions should be retained for future reference.

- 1 **Power sources.** The unit should be connected to a power supply only of the type described in this manual or as marked on the unit. If you are not sure of the type of power supply to your home, consult your unit dealer or local power company. For units intended to operate from battery power, or other sources, refer to the instruction manual.
- 2 **Power-cord protection.** Power supply cords should be routed so that they are not likely to be walked on or pinched by items placed upon or against them, paying particular attention to cords at plugs, convenience receptacles, and the point where they exit from the unit.
- 3 **CAUTION—Polarization.** This unit may be equipped with a polarized alternating-current line plug (a plug having one blade wider than the other). This plug will fit into the power outlet only one way. This is a safety feature. If you are unable to insert the plug fully into the outlet, try reversing the plug. If the plug should still fail to fit, contact your electrician to replace your outlet. Do not defeat the safety purpose of the polarized plug.
- 4 **Ventilation.** Slots and openings in the cabinet are provided for ventilation and to ensure reliable operation of the unit and to protect it from overheating, and these openings must not be blocked or covered. The unit should be situated so that its location or position does not interfere with its proper ventilation.
 - To maintain good ventilation, do not put records or a table-cloth on the unit. Place the unit at least 4 inches away from the walls.
 - Do not use the unit on a bed, sofa, rug or similar surface that may block the ventilation openings. This unit should not be placed in a built-in installation such as a bookcase or rack unless proper ventilation is provided or the manufacturer's instructions have been adhered to.
- 5 **Water and moisture.** The unit should not be used near water; for example, near bathtub, washbowl, kitchen sink, laundry tub, in a wet basement, or near a swimming pool, etc.
- 6 **Temperature.** The unit may not function properly if used at extremely low or freezing temperatures. The ideal ambient temperature is above +41°F.
- 7 **Heat.** The unit should be situated away from heat sources such as radiators, heat registers, stoves, or other units (including amplifiers) that produce heat.
- 8 **Electric Shock.** Care should be taken so that objects do not fall and liquid is not spilled into the enclosure through openings. If a metal object, such as a hair pin or a needle, comes

into contact with the inside of this unit, a dangerous electric shock may result. For families with children, never permit children to put anything, especially metal, inside this unit.

- 9 **Enclosure removal.** Never remove the enclosure. If the internal parts are touched accidentally, a serious electric shock might occur.
- 10 **Cleaning.** Unplug this unit from the wall outlet before cleaning. Do not use volatile solvents such as alcohol, paint thinner, gasoline, or benzine, etc. to clean the cabinet. Use a clean dry cloth.
- 11 **Lightning.** For added protection for this unit during a lightning storm, or when it is left unattended and unused for long periods of time, unplug it from the wall outlet and disconnect the antenna or cable system. This will prevent damage to the unit due to lightning and power-line surges.
- 12 **Abnormal smell.** If an abnormal smell or smoke is detected, immediately turn the power OFF and unplug the unit from the wall outlet. Contact your dealer or nearest service center.
- 13 **Damage requiring service.**

The unit should be serviced by qualified service personnel when:

 - The power-supply cord or the plug has been damaged.
 - Objects have fallen, or liquid has been spilled into the unit.
 - The unit has been exposed to rain or water.
 - The unit has been dropped; or the enclosure damaged.
 - The unit exhibits a marked change in performance.
 - The unit does not appear to operate normally by following the instruction manual.
 - Adjust only those controls that are covered by the instruction manual, as an improper adjustment of other controls may result in damage and will often require extensive work by a qualified technician to restore the unit to its normal operation.
- 14 **Servicing.** The user should not attempt to service the unit beyond that described in the instruction manual. All other servicing should be referred to qualified service personnel.
- 15 **Power lines.** An outside antenna system should not be located in the vicinity of overhead power lines or other electric light or power circuits, or where it can fall into such power lines or circuits. When installing an outside antenna system, extreme care should be taken to keep from touching such power lines or circuits as contact with them might be fatal.
- 16 **AC outlets.** Do not connect other audio equipment with a power consumption larger than that specified to the AC outlet on the rear panel. Never connect other electrical units, such as an iron or toaster, to it to prevent fire or electric shock.
- 17 **Overloading.** Do not overload wall outlets, extension cords, or integral convenience receptacles as this can result in a risk of fire or electric shock.
- 18 **Attachment.** Do not use attachments not recommended by the unit manufacturer as they may cause hazards.
- 19 **Replacement parts.** When replacement parts are required, be sure the service technician has used replacement parts specified by the manufacturer or have the same characteristics as the original parts. Unauthorized substitutions may result in fire, electric shock, or other hazards.
- 20 **Safety check.** Upon completion of any service or repairs to this unit, ask the service tech-

nician to perform safety checks to determine that the unit is in proper operating condition.

21 Carts and stands. Don't put this unit on a cart or stand that is unsteady or that can not support the unit's weight. If you move this unit on a cart or stand, be careful—quick stops, excessive force and pushing over or uneven surfaces, may cause the cart to overturn and damage your equipment.

22 Outdoor Antenna Grounding. If an outside antenna is connected to the receiver, be sure the antenna system is grounded to provide some protection against voltage surges and built-up static charges. Section 810 of the National Electrical Code, ANSI/NFPA 70, provides information on the proper grounding of the mast and supporting structure, grounding of the lead-in wire to an antenna discharge unit, size of grounding conductors, location of antenna-discharge unit, connection to grounding electrodes and requirements for the grounding electrode. NOTE: Complies with UL in the U.S.A.

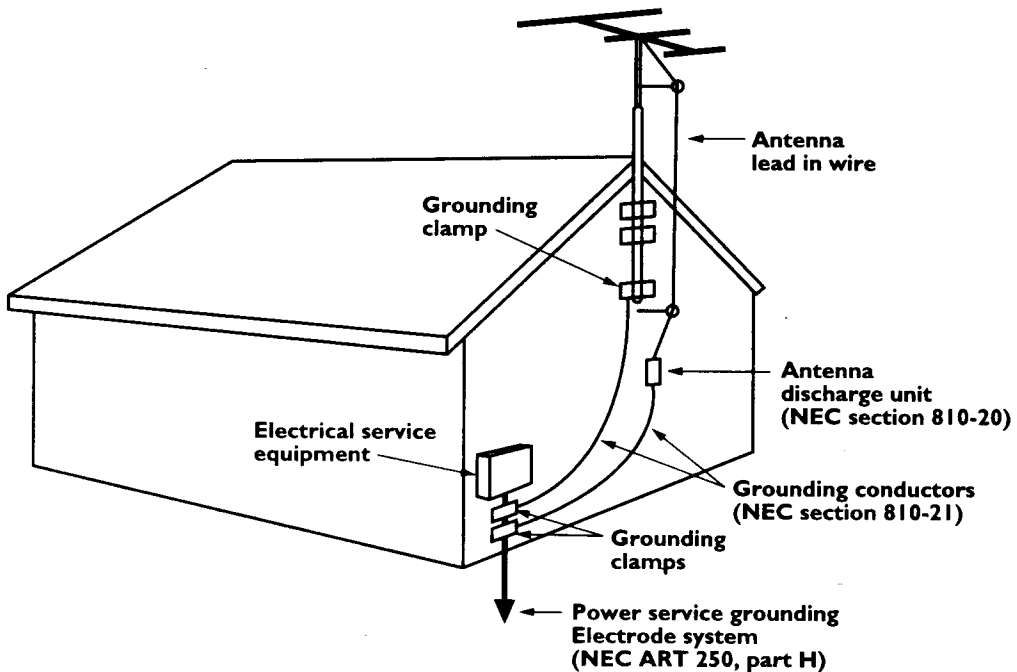

23 TouchPanel. Handle the TouchPanel carefully. Do not drop the TouchPanel or its rechargeable batteries onto a hard surface. If the TouchPanel's LCD screen is damaged or fractured, do not put any of the liquid substance into your mouth. If any of the liquid substance comes into contact with skin or clothing, immediately wash it off with soap and water.

FCC Warning

This equipment may generate or use radio frequency energy. Changes or modifications to this equipment may cause harmful interference unless the modifications are expressly approved in the instruction manual. The user could lose the authority to operate this equipment if an unauthorized change or modification is made.

Important

This equipment has been tested and found to comply with the limits for a Class B digital device, pursuant to Part 15 of the FCC Rules. These limits are designed to provide reasonable protection against harmful interference in a residential installation. This equipment may cause harmful interference to radio communications if it is not installed and used in accordance with the instructions. However, there is no guarantee that interference will not occur in a particular installation. If this equipment does cause harmful interference to radio or television reception, which can be determined by turning the equipment OFF and ON, the user is encouraged to try to correct the interference by one or more of the following measures:

- Reorient or relocate the receiving antenna
- Increase the separation between the equipment and receiver
- Connect the equipment into an outlet on a circuit different from that to which the receiver is connected
- Consult the dealer or an experienced radio/TV technician for help

Canadian IC Compliance Notice

This device complies with RSS-210 of Industry Canada. Operation is subject to the following two conditions: (1) this device may not cause interference, and (2) this device must accept any interference, including interference that may cause undesired operation of the device.

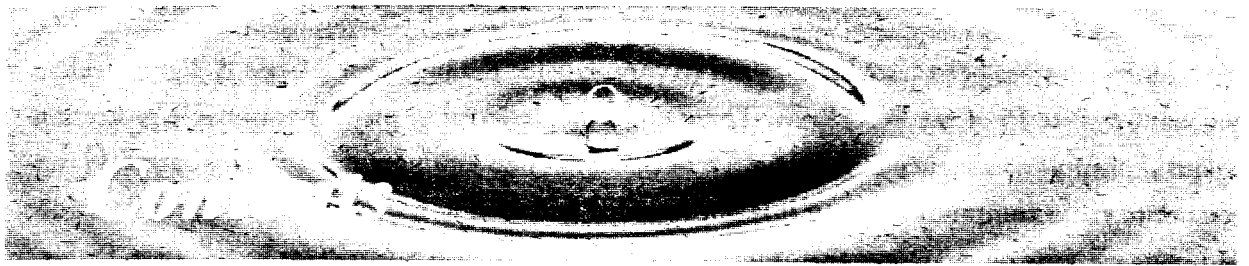

Safety first	3
Contents	8
Unpacking your Stage 3 Controller	10
Did you get everything?	10
In this box you should have	10
You may need to purchase	11
You may also need these tools	11
For your records	11
Welcome	12
STEP 1: Placing the Stage 3 Controller	13
STEP 2: Connecting a power amplifier	14
Connecting a Stage 3 Power Amplifier	14
Connecting any other power amplifier(s)	15
Connecting a secondary power amplifier	16
STEP 3: Connecting your video components	17
About S-video	17
Connecting your VCRs	18
Connecting your laser disc or DVD player	19
Connecting your cable or satellite TV tuner	20
Connecting your TV	21
STEP 4: Connecting audio components	22
Connecting your CD or DVD player	23
Connecting your turntable	24
Connecting your analog tape decks	25
Connecting your MiniDisc recorder	26
Connecting a graphic equalizer	27
STEP 5: Connecting the antennas	28
Using the AM indoor loop antenna	28
Using an AM outdoor antenna	28
Using the FM indoor antenna	29
Using an FM outdoor antenna	29
STEP 6: Connecting components for TouchPanel control	31
Connecting Kenwood components	31
About XS8 components	31
Kenwood SL-16-type components	32
Other components	33
Controlling accessories	34

STEP 7: Turning the power on for the first time	35
STEP 8: Preparing the TouchPanel	36
About the TouchPanel	36
Installing the battery in the TouchPanel	37
Attaching the TouchPanel to the Dock	38
Charging a battery	40
About battery life	41
About the rechargeable batteries	41
STEP 9: Customizing the TouchPanel	42
Calibrating the TouchPanel	43
About the Main menu	44
About the auto-off feature	44
Changing the LCD contrast	45
Creating a set-up security code	46
To turn off the security code	47
If you forget your security code	47
Setting the LCD screen saver	48
Changing the communication channel	49
Setting the time	50
STEP 10: Setting up audio and video components	51
Basic procedure	51
Setting up IR codes	53
Setting up a CD player	55
Setting up a cassette deck	56
Setting up a laser disc player	56
Setting up a mini disc recorder	56
Setting up a VCR.....	57
Setting up a TV	57
Setting up a satellite receiver or cable TV tuner	57
Setting up a turntable	57
Setting up a DVD player	58
STEP 11: Setting up speakers	62
About default settings	62
Setting up the front speakers	63
Setting up the center and surround speakers	64
Setting up the subwoofer	65
Setting the bass limiter	66
STEP 12: Balancing the speaker sound levels	68
Balancing the speaker levels by ear	69
About balancing the subwoofer level	70
Balancing the speaker levels with a sound level meter	70
STEP 13: Setting up DSP Logic.....	72
Set-up codes	74



Unpack your Stage 3 Controller carefully and examine it for shipping damage. If it is damaged or fails to operate, notify your dealer immediately. If this product was shipped to you directly, notify the shipping company without delay. Only the person or company who originally received the product can file a claim against the carrier for shipping damage. Keep the original carton and packing materials in case you need to transport or ship your Stage 3 Controller.

Did you get everything?

Check the list below to make sure you have everything. And before you start setting up the system, look at the list of tools and other items you'll need.

In this box you should have

- Stage 3 Controller unit

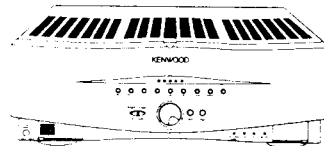

- TouchPanel

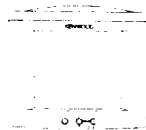

- Batteries for TouchPanel (2)



- Infra-Red (IR) Repeater

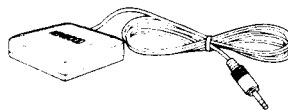

- Audio cables (3)



- System Control cable

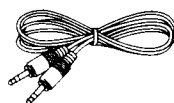

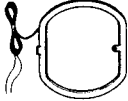
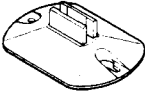
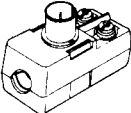
- FM indoor antenna 
- AM loop antenna 
- AM loop antenna stand 
- Antenna adaptor 

You may need to purchase:

Audio cables

Video cables

S-Video cables (for TVs with S-Video capability only)

RF modulator (for TVs without video inputs)

Speaker wire (as needed)

You may also need these tools:

Screwdriver (slot and/or Phillips)

Pliers

Wire cutters

Wire strippers

Sound level meter (Radio Shack part #33-2050)

For your records

Record the serial number (found on the back of the unit) on the warranty card, and in the space below. If you need to call your dealer for information or service, you'll need the model and serial number. And be sure to save your original purchase receipt.

Model Number: KC-Z1

Serial Number:

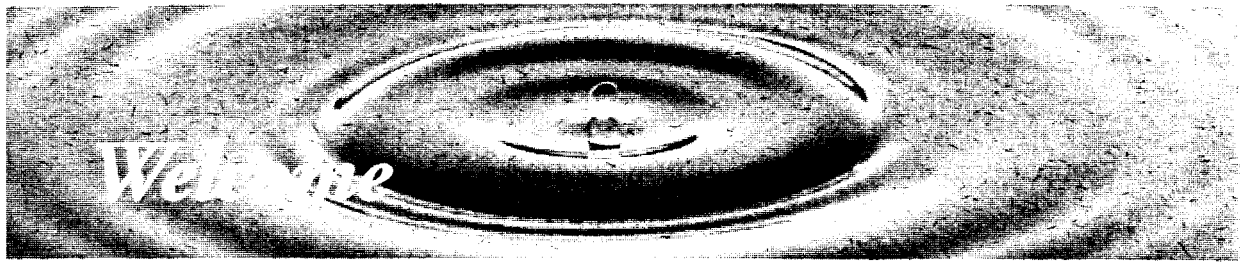

We designed the Stage 3 Controller to totally change the way you operate your audio/video system. And we're sure that Stage 3 will simplify your home entertainment experience.

We've tried to make setting up your system as easy as possible, too. However, since the Stage 3 Controller works with all of your audio and video components, connecting the system can be fairly complex.

This guide is divided into easy-to-follow steps. Some steps are optional, and if they don't apply, just skip ahead to the next step.

Be sure to use these instructions along with those in the manuals for any equipment you're connecting (like CD players, cassette decks, laser disc players, DVD players, satellite or cable tuners, televisions, amplifiers, equalizers, VCRs or speakers).

Finally, thanks for purchasing this Stage 3 Controller. We hope it brings you years of music and home theater enjoyment.

Placing the Stage 3 Controller **step 1**

The Stage 3 Controller's high power digital processing can produce a lot of heat, so it's important to allow plenty of ventilation.

- Do not place the Stage 3 Controller directly on top of a heater or a heat-generating component (such as a power amplifier). The heat may prevent the recharging of the TouchPanel batteries.
- Leave at least 4 inches of space above the controller.
- Leave at least 2 inches of space behind, and on each side of the controller.
- If you place the controller inside a stereo rack or cabinet, make sure that you leave the door open slightly while the controller is on.

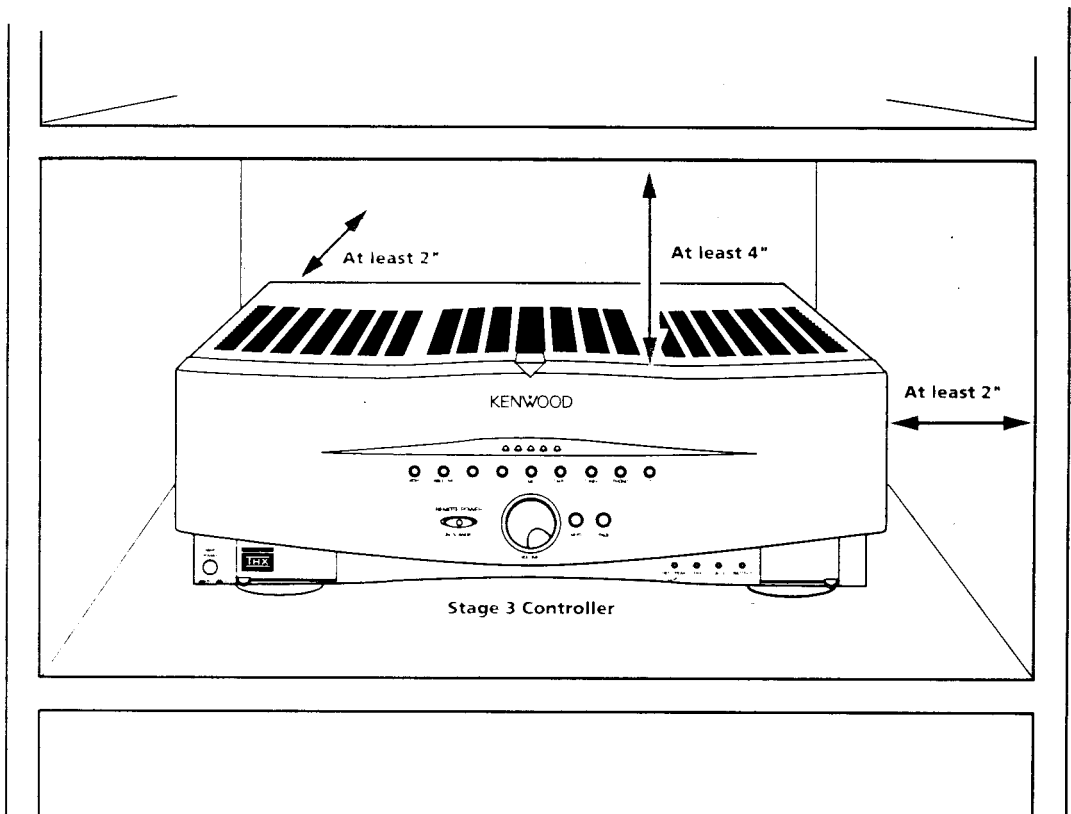

Connecting a power amplifier step 2

Please wait until you've connected all of the cables before plugging the controller into the AC wall outlet and turning it on.

Connecting a Stage 3 Power Amplifier

To connect the Stage 3 Controller to the Stage 3 Amplifier, you can use the 6 cables that come with the amplifier, or use a DB-25 cable you buy yourself. If you decide to use a DB-25 cable, we recommend that you use a shielded DB-25 cable (such as the Monster Cable I-206 HTDB). For more information, contact the dealer where you purchased your Stage 3 Controller. Do not use the DB-25 cable and the individual preout cables at the same time.

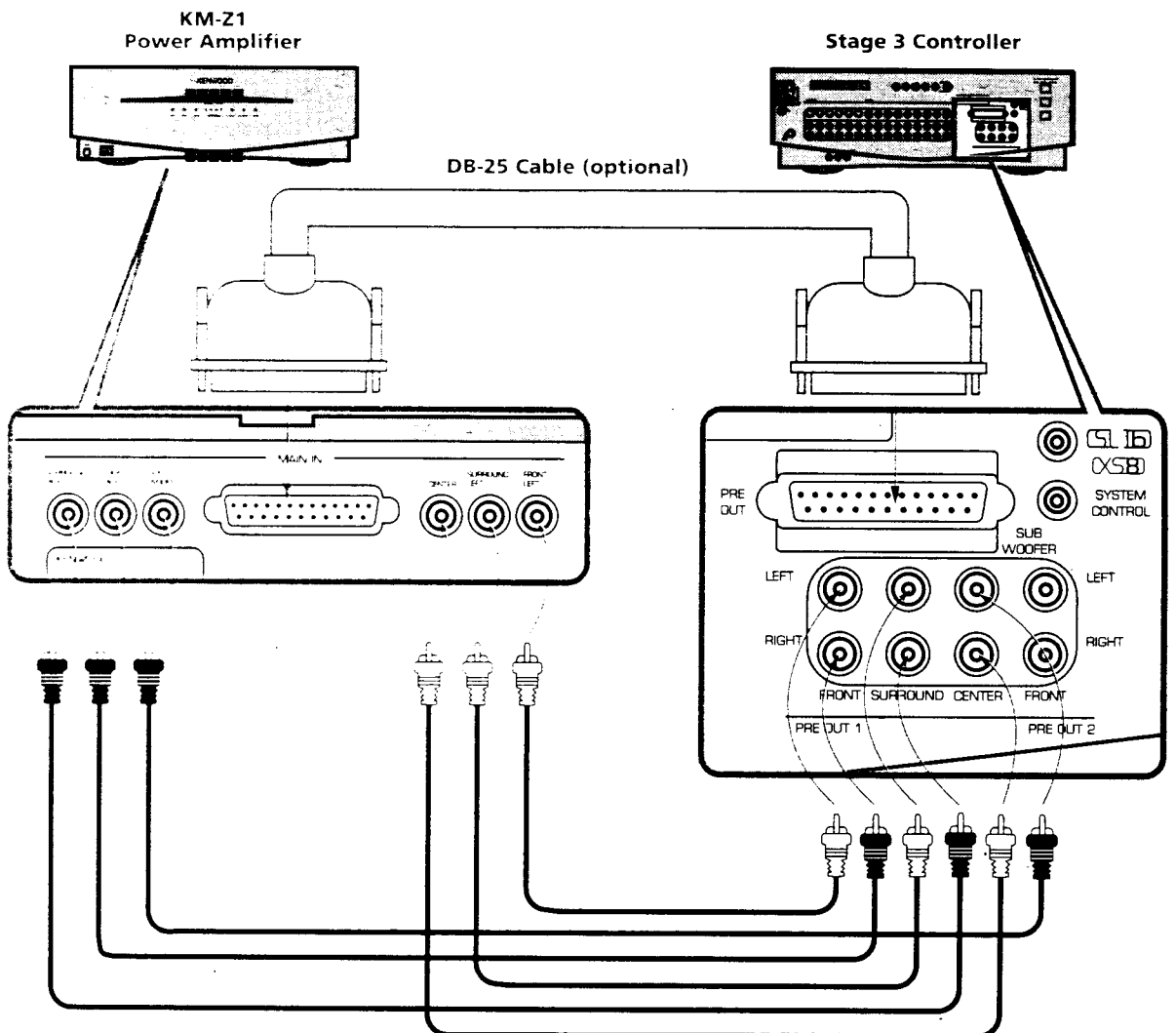

Connecting any other power amplifier(s)

You can use the Stage 3 Controller preout jacks to connect up to 3 amplifiers to drive front, surround, and subwoofer speakers. Using the supplied audio cables, connect the 6 Preout-1 jacks on the Stage 3 Controller to the input jacks on the power amplifier(s). To connect your speakers, refer to the manuals for the power amplifiers and the individual speakers.

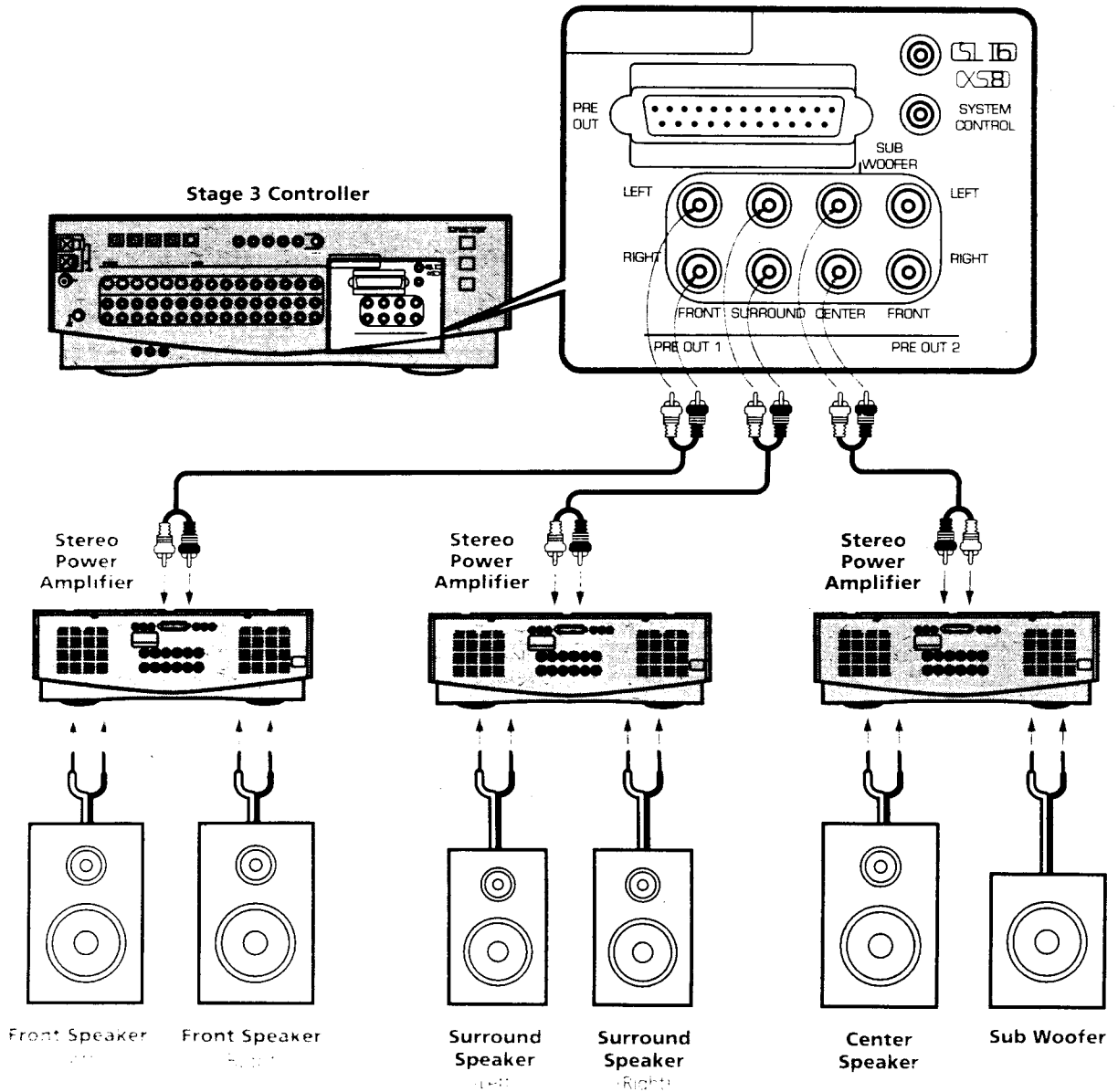

Connecting a secondary power amplifier

You can use the Stage 3 Controller's Preout-2 jacks to connect a secondary power amplifier to drive speakers elsewhere in the home. You can adjust the volume of the secondary amplifier and speakers separately from the volume of the main amplifier and speakers. (Refer to page 9 of *Using your Stage 3 Controller* for instructions on how to adjust the volume level.) Sound will play through the secondary speakers as well as the main speakers. Using a pair of audio cables (not supplied), connect the secondary amplifier to the Stage 3 Controller.

Note: Only sources connected using analog inputs will play through the Preout-2 outputs. Refer to *Using your Stage 3 Controller* for instructions on selecting a source's analog inputs.

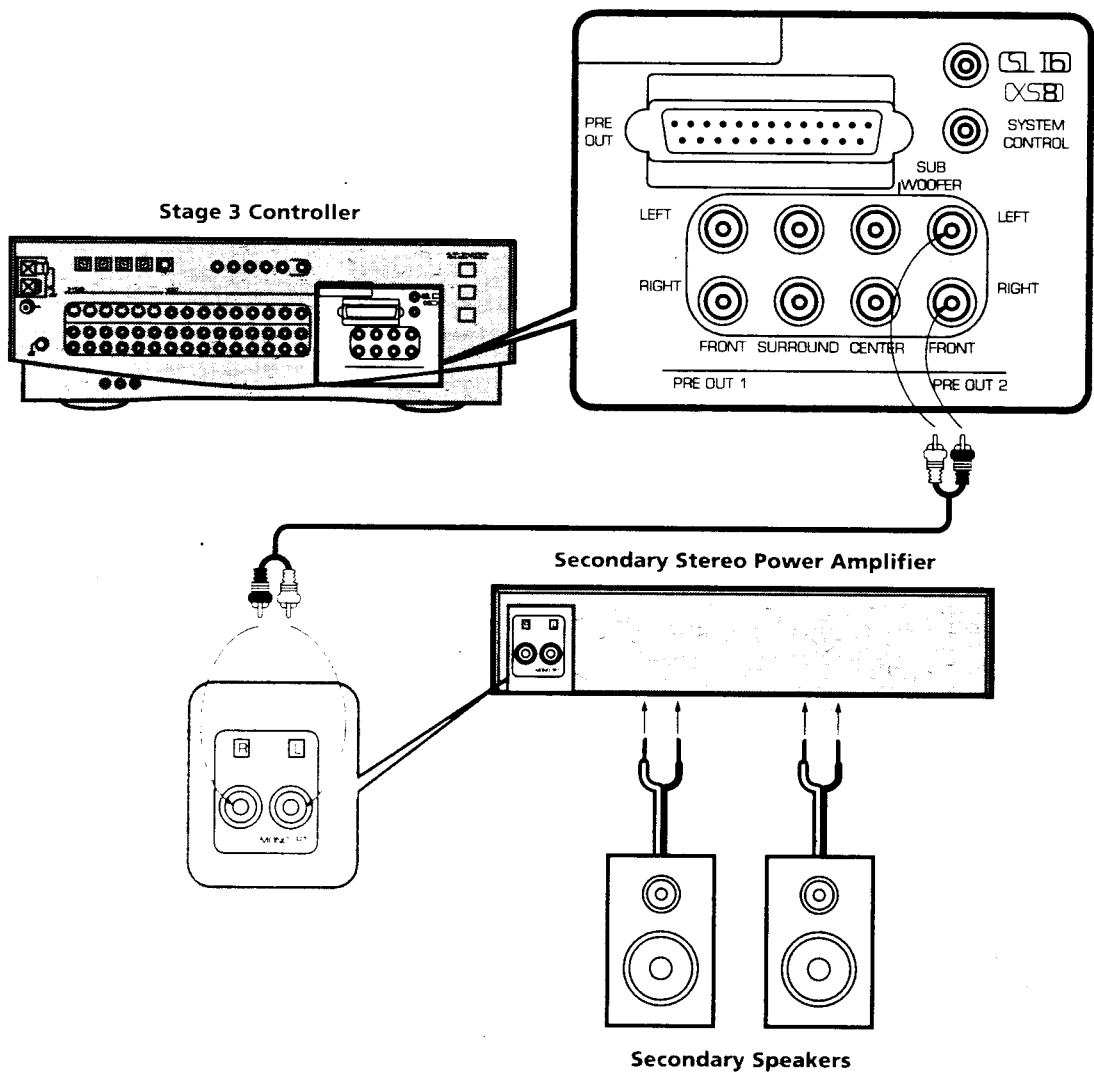

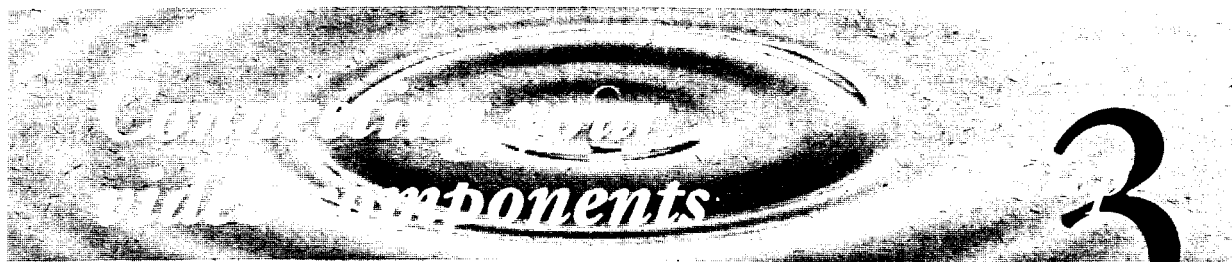

You can connect your television, laser disc player, cable or satellite TV tuner, 2 VCRs and a camcorder to the Stage 3 Controller. You can also connect a DVD player in place of a laser disc player. Be sure to read the manuals that come with your video components for more instructions.

- Make sure that you connect the plugs firmly, so there's no sound loss or unwanted noise later.
- Whenever you connect or disconnect cables, turn off the power and unplug the power cord from the AC wall outlet to avoid damaging your unit.
- The cables are not included with the Stage 3 Controller.
- For more instructions, read the manual that came with each component.

About S-video

If your video components have S-video capability, using the S-video jacks will provide superior video performance.

- If you use the S-video jacks, you must use them for both the video source and TV connections. Composite video sources are not output through the Stage 3 Controller's S-video outputs (and vice versa).

Connecting your VCRs

You can connect up to two VCRs to the Stage 3 Controller.

- If you use the S-video jack, do not connect the Video Play Out or Video Record In cables.

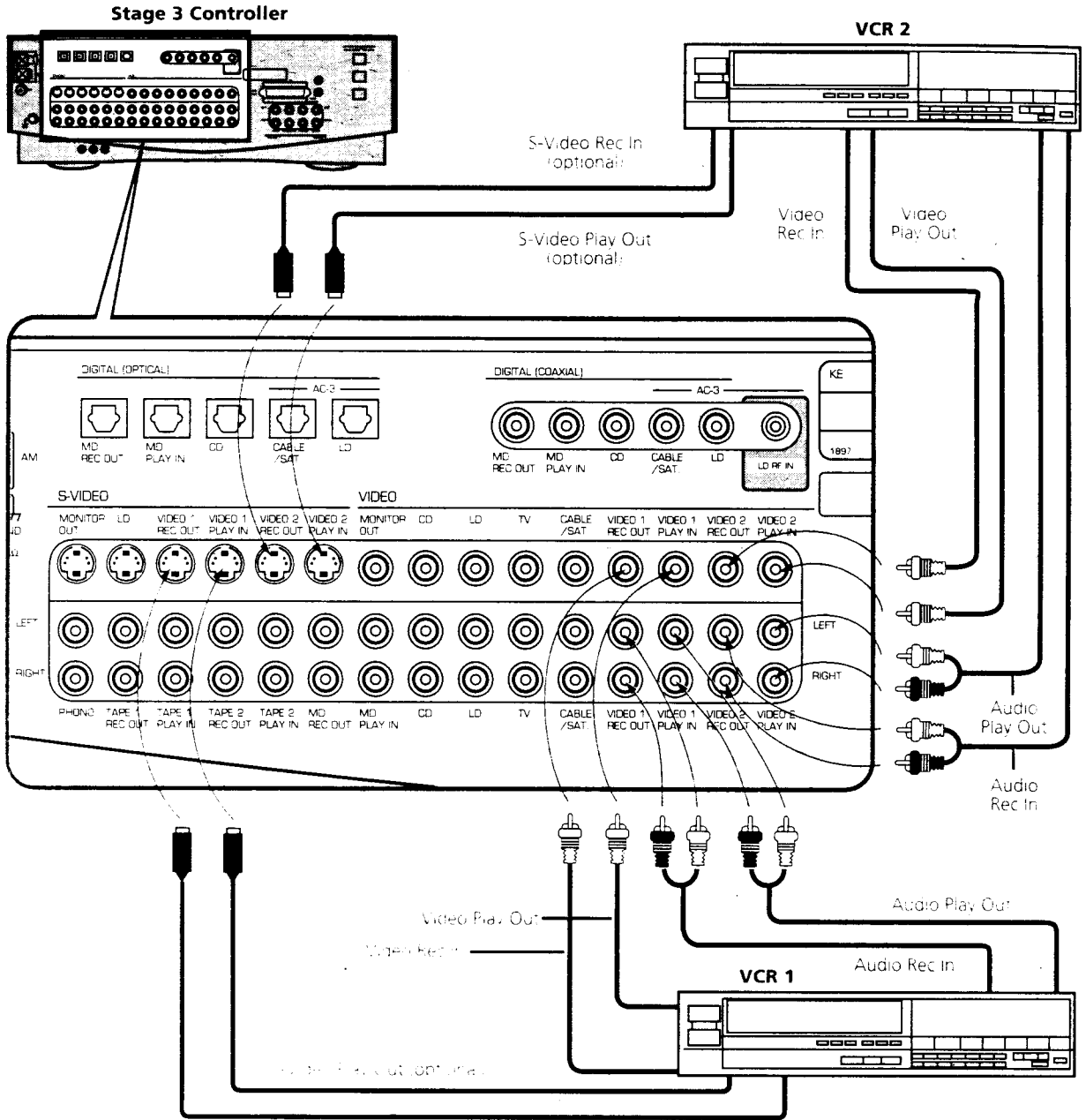

- You can use the Video 3 input (on the front panel) to connect a play-only video source, such as a camcorder, laser disc player, or another VCR.

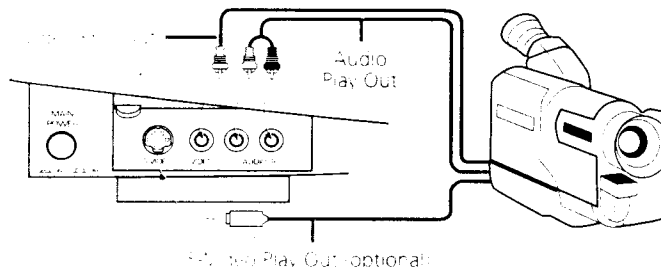

Connecting your laser disc or DVD player

Connect the Composite Video Out and Audio Out cables to the Stage 3 Controller. If your player has Digital Optical or Digital Coaxial Out, AC-3 RF Out, or S-video, connect them also.

- If you use the S-video connection, do not use the Composite Video Out jack.
- You cannot use DVD component video connections.
- If you want to connect both a DVD player and laser disc player to the Stage 3 Controller, connect the DVD player to the CD Input. (See page 23, step 4).

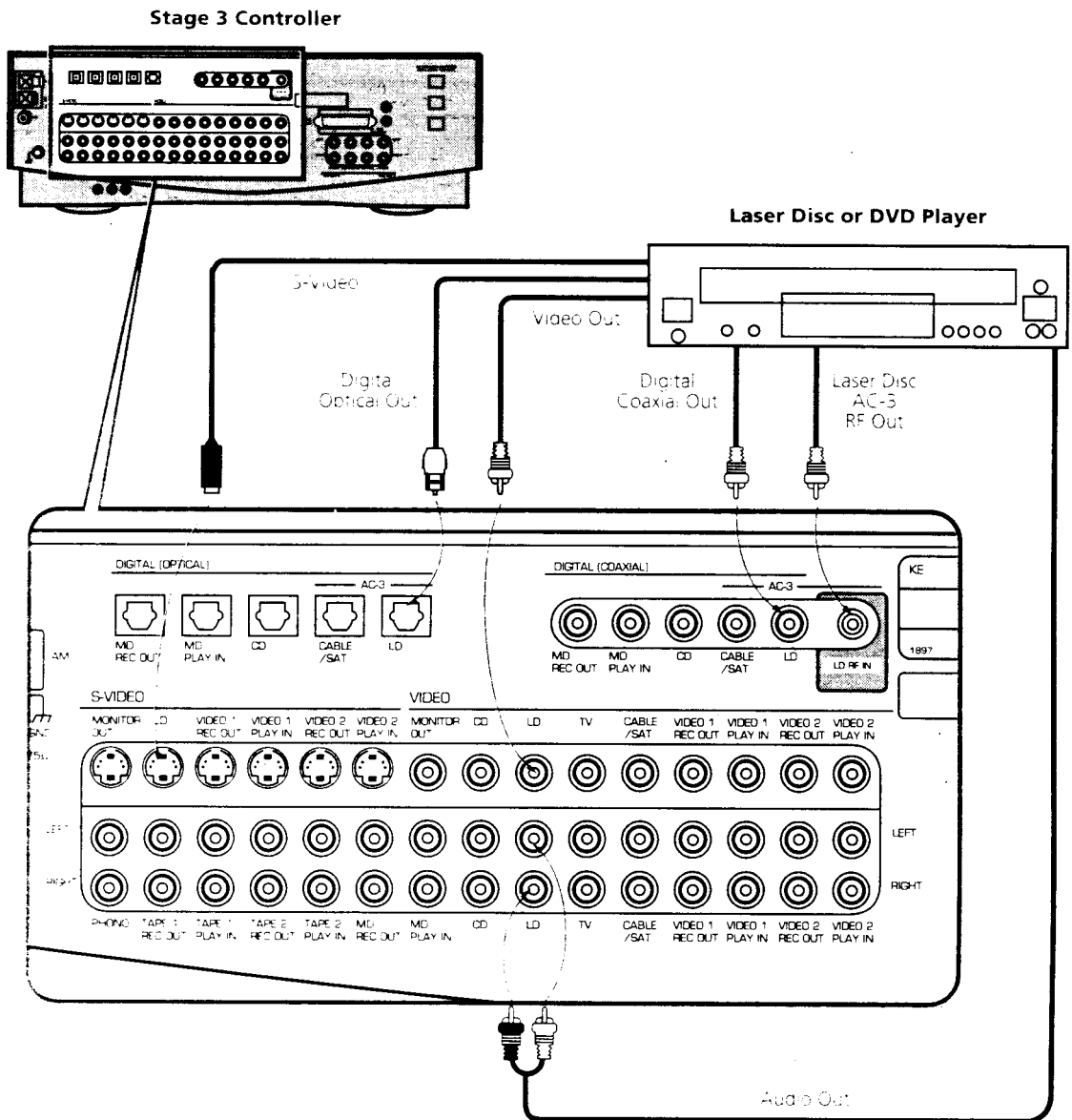

Connecting your cable or satellite TV tuner

Connect the Video Out and Audio Out cables to the Stage 3 Controller. If you have Digital Optical, or Digital Coaxial cables, connect them also.

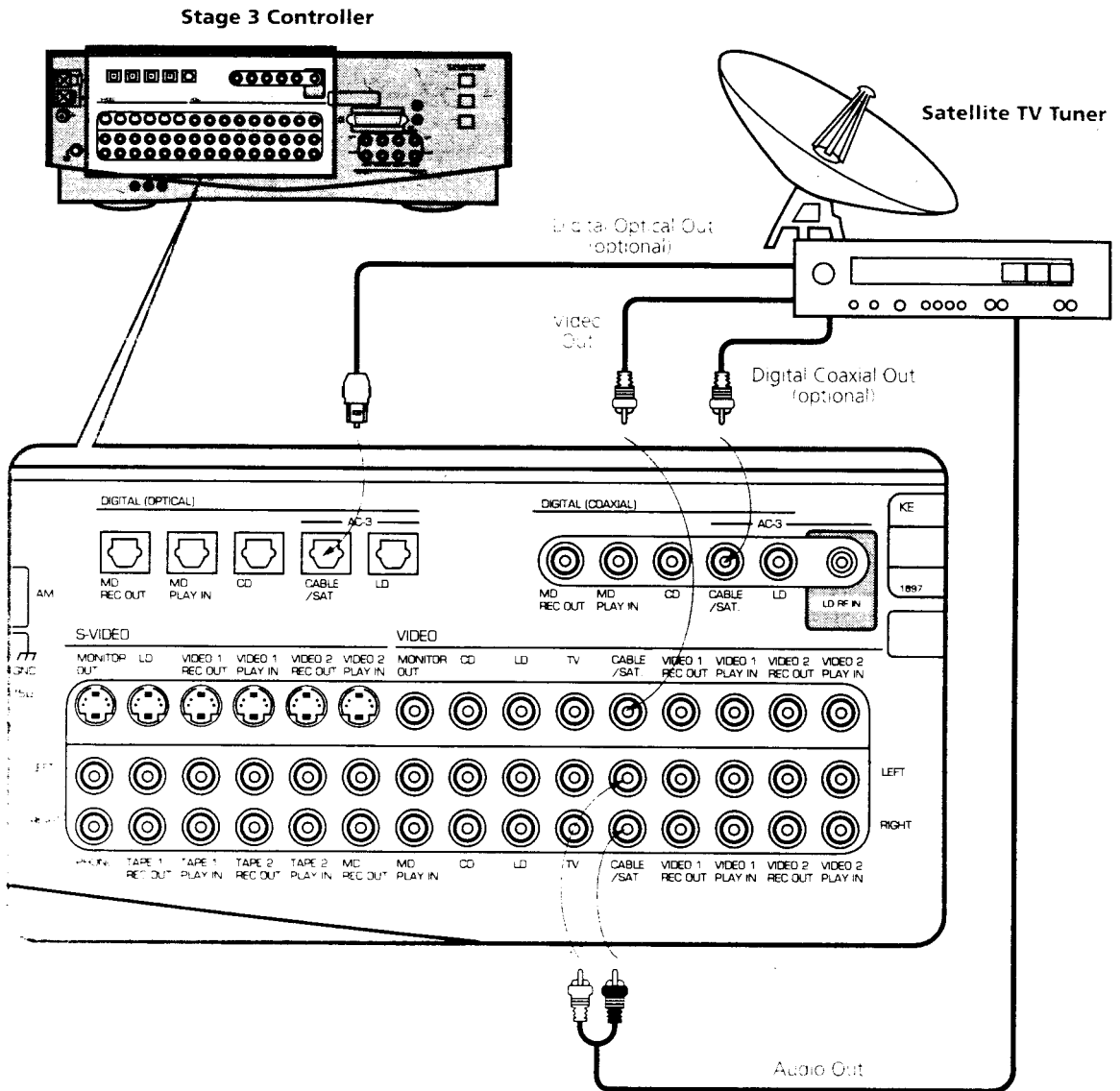

Connecting your TV

Connect the Video In cable to the Stage 3 Controller. If you have Video Out, Audio Out, or S-video, connect them also.

- If you use the S-video jack, do not use the Video In or Video Out jacks.

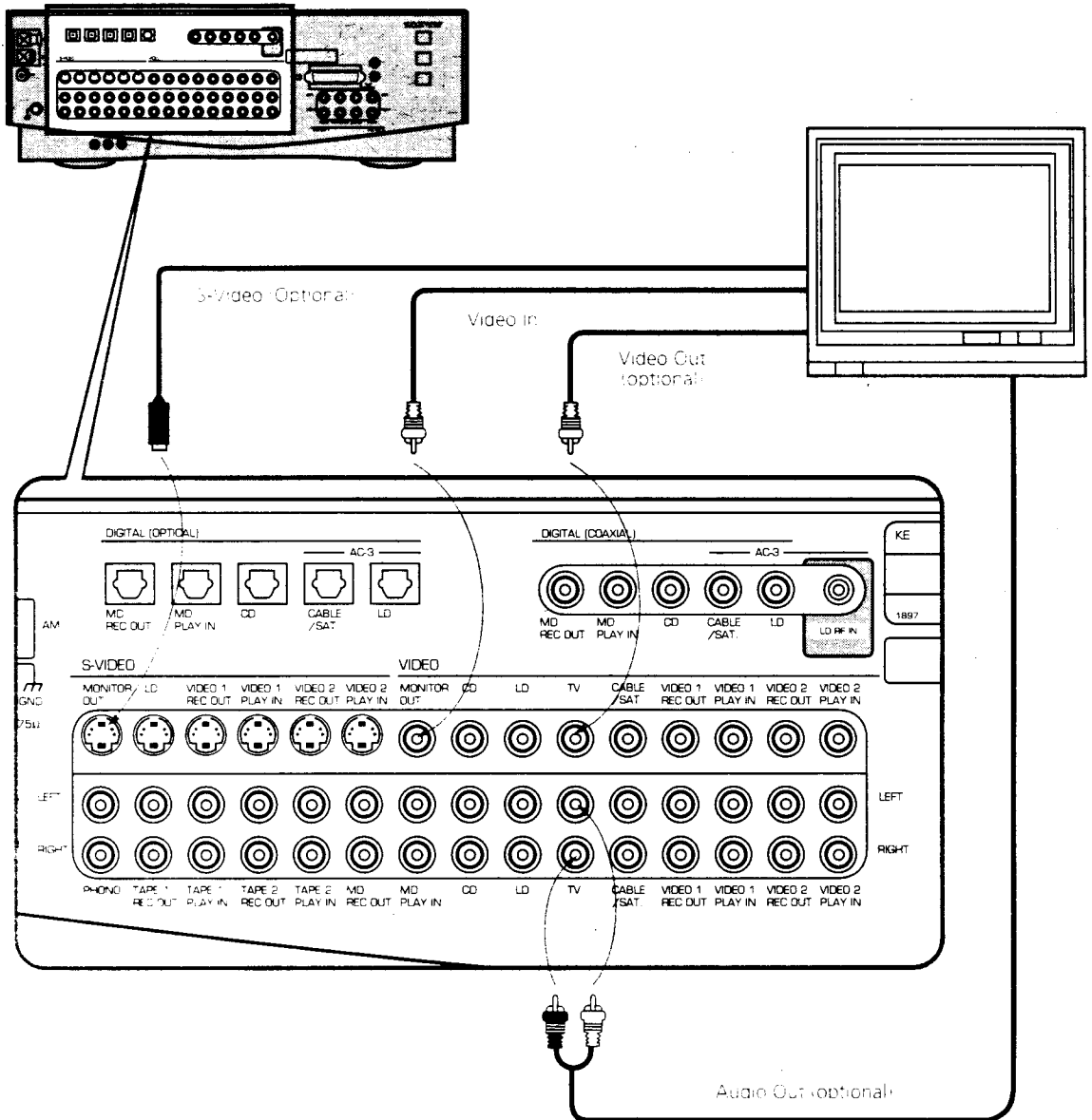

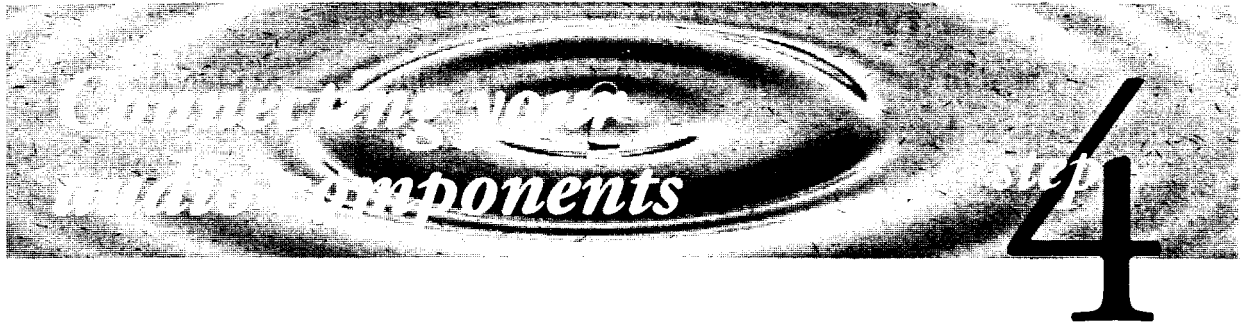

You can connect your turntable, CD player, 2 analog tape decks, and a MiniDisc recorder (or a third tape deck) to the Stage 3 Controller. You can also connect a DVD player in place of a CD player.

- Make sure that you connect all plugs firmly, so there's no sound loss or unwanted noise later.
- Whenever you connect or disconnect cables, turn off the power and unplug the power cord from the AC wall outlet to avoid damaging your unit.
- The cables are not included with the Stage 3 Controller.
- For more instructions, read the manual that came with each component.

Connecting your CD or DVD player

Connect the Audio Out and Composite Video Out cables to the Stage 3 Controller. If your player has Digital Coaxial or Digital Optical Out, connect them also.

- You cannot use DVD component video connections.
- If you want to connect both a DVD player and CD player to the Stage 3 Controller, connect the DVD player to the Laser Disc Input. (See page 19, step 3).

Note: If you are connecting a Kenwood 100-disc CD changer, be sure to plug its power cord into one of the switched outlets on the Stage 3 Controller. This will ensure that the TouchPanel can properly control the CD changer.

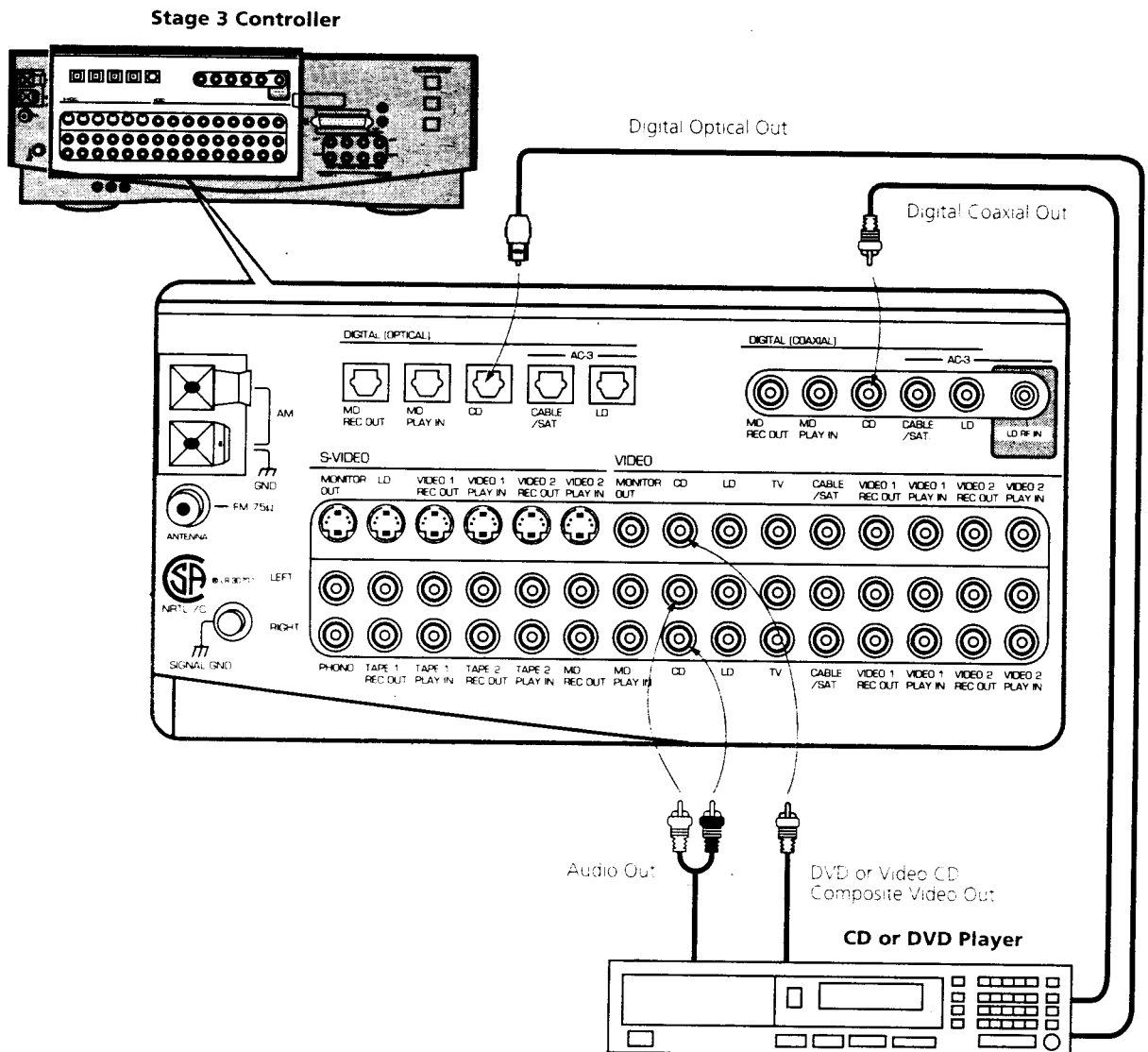

Connecting your turntable

Connect the Audio Out and Ground Wire to the Stage 3 Controller.

Stage 3 Controller

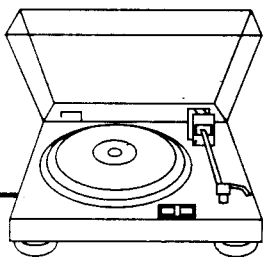
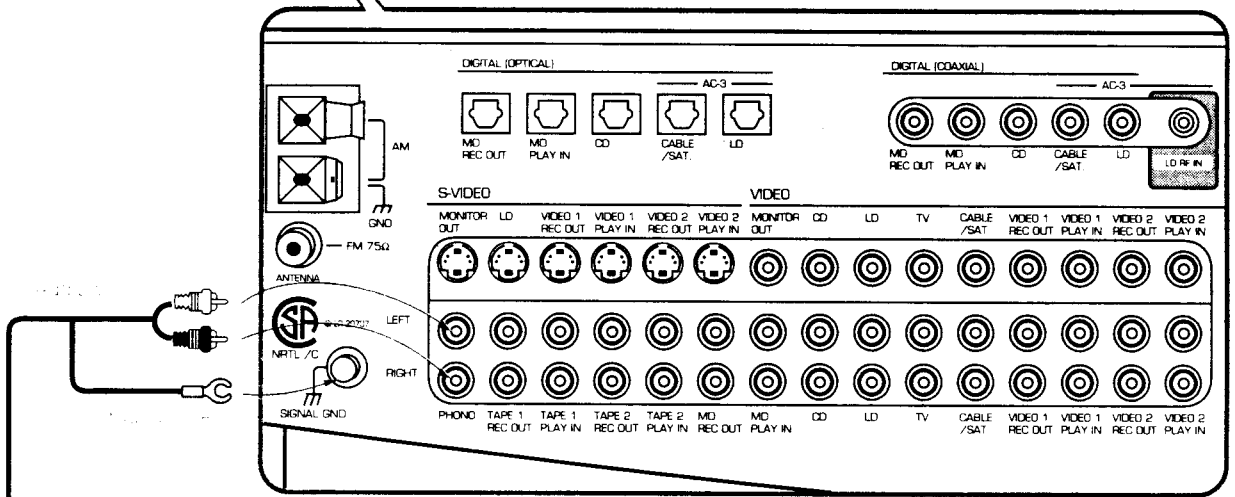
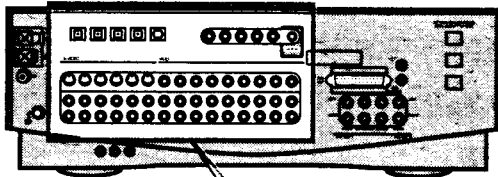

Turntable

Connecting your analog tape decks

You can connect up to two analog tape decks, such as a cassette deck or reel-to-reel.

Connect the Record In and Play Out cables to the Stage 3 Controller.

- If you have a Kenwood tape deck with SL16 System Control jacks (see page 32), connect it to the Tape-1 inputs.
- Read *Using your Stage 3 Controller* for instructions on how to use Tape-2 as a tape monitor input.
- If you are not using a MiniDisc recorder, you can connect a third analog tape deck to the Stage 3 Controller's analog MD Play In and MD Rec Out inputs. In this case, leave the Stage 3 Controller's digital MD inputs and outputs open.

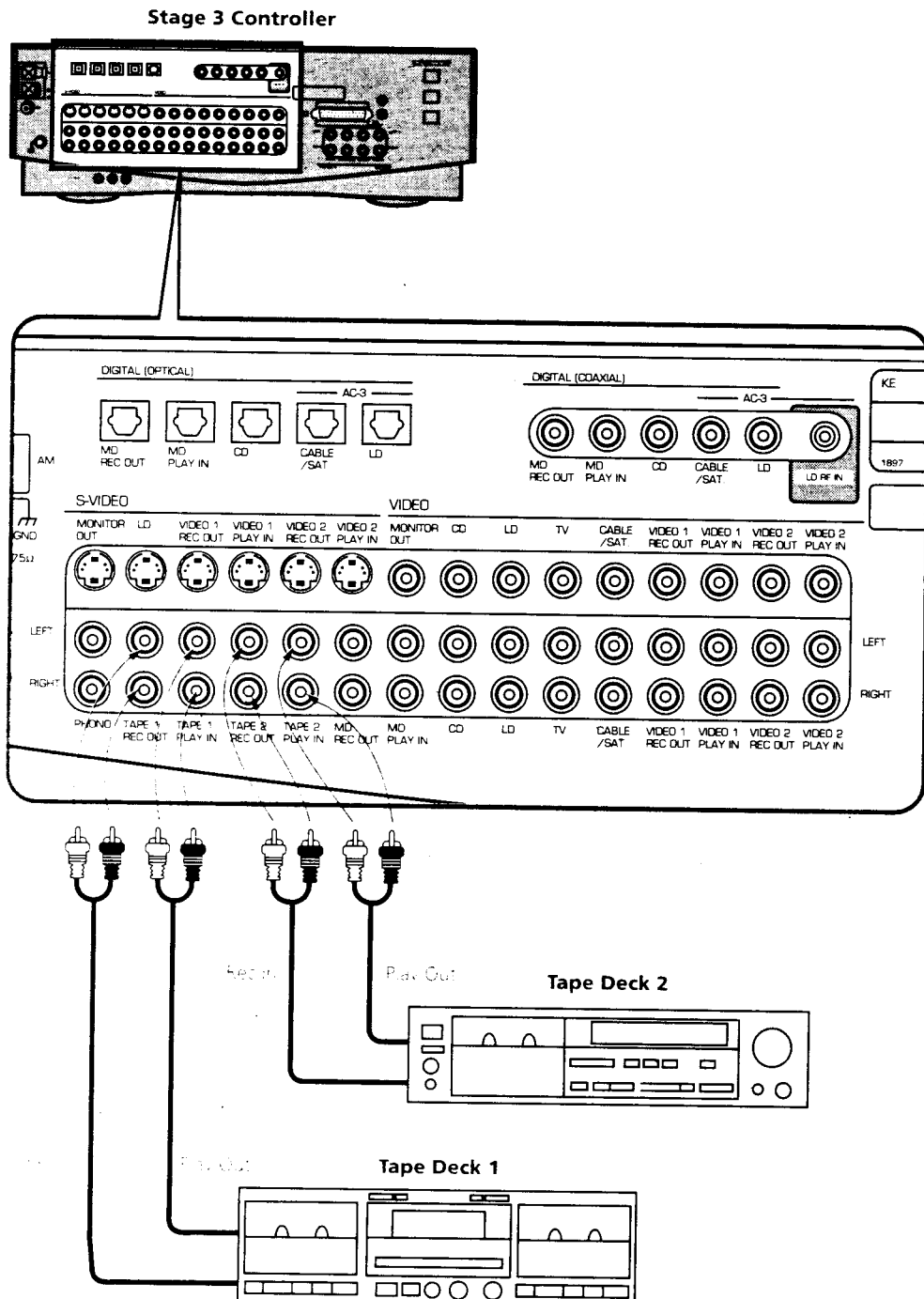

Connecting your MiniDisc recorder

Connect the analog Play Out, Analog Record In, and any of the Digital Optical Record In, Digital Optical Record Out, Digital Coaxial Record In, or Digital Coaxial Play Out cables to the Stage 3 Controller.

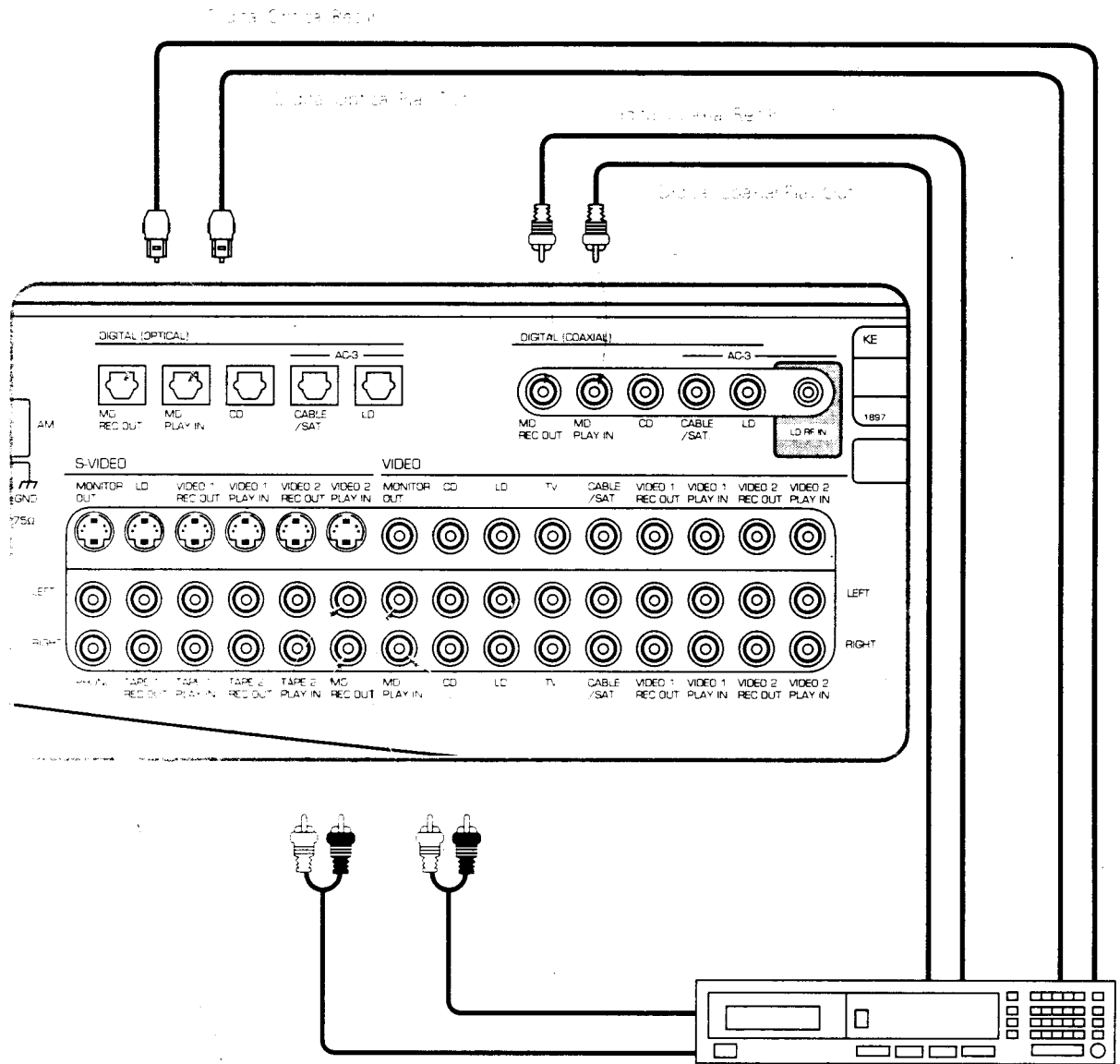

MiniDisc Recorder

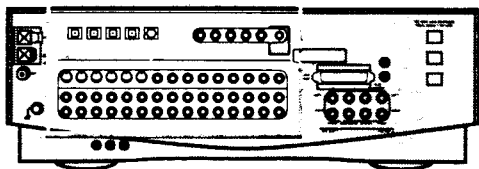

Stage 3 Controller

Connecting a graphic equalizer

If you connect a graphic equalizer to the Stage 3 Controller, be sure to connect it between the Stage 3 Controller's Pre Out 1 or Pre Out 2 and your power amplifier's inputs.

- **IMPORTANT:** Do not connect a graphic equalizer to the Tape 2 jack and configure it as a tape monitor input. This could overload the Stage 3 Controller's digital circuitry, causing distortion and interfering with Dolby Surround Pro Logic performance.

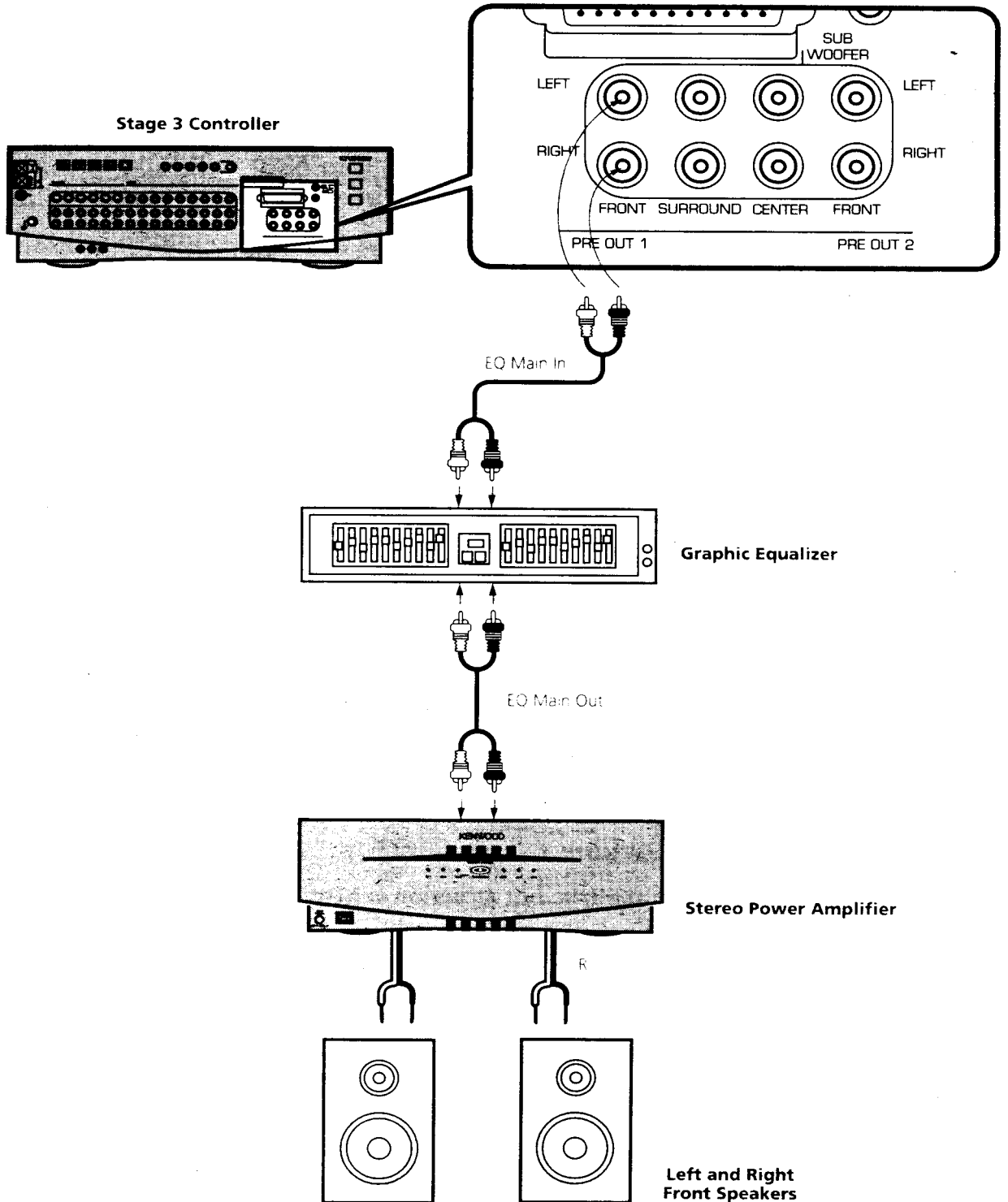



Antennas play an important role in the FM/AM reception of your Stage 3 Controller. The quality of this reception depends on how well you install and position the antennas.

Using the AM indoor antenna

- 1 Connect the AM antenna wires to the Stage 3 Controller AM antenna terminals.
- 2 Place the antenna as far away as possible from the main system, television, speaker wires, and power cords.
- 3 If you're using the antenna stand, attach the antenna by inserting the antenna loop into the clip on the top of the stand.
- 4 Rotate the antenna until you get the best reception.

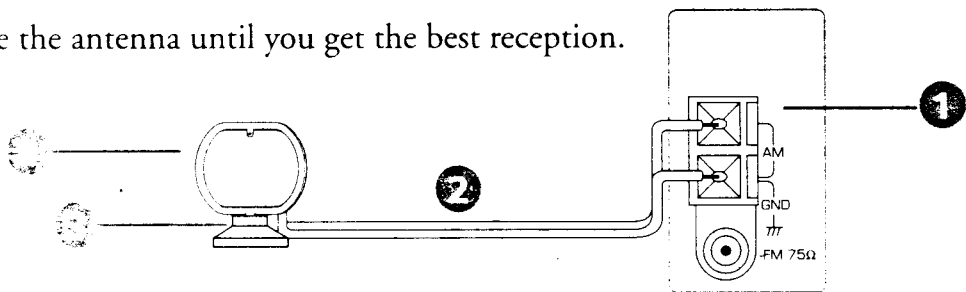

Using an AM outdoor antenna (optional)

If you're using the AM indoor antenna, but reception is poor, install an AM outdoor antenna at least 20 feet long. Do not disconnect the indoor antenna.

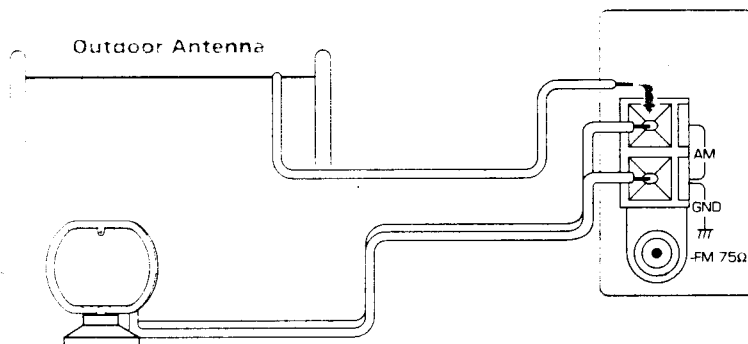

Using the FM indoor antenna

You can use the FM indoor antenna we've supplied until you can install an outdoor antenna. When you do, remove the indoor antenna.

- 1 Connect the loose ends of the antenna to the screw terminals on the antenna adaptor.
- 2 Connect the antenna adaptor to the Stage 3 Controller antenna input.
- 3 Fully extend the antenna and place it along a wall or bookshelf.
- 4 Adjust the antenna to find the position that provides the best reception.
- 5 Affix the two ends to the wall or bookshelf.

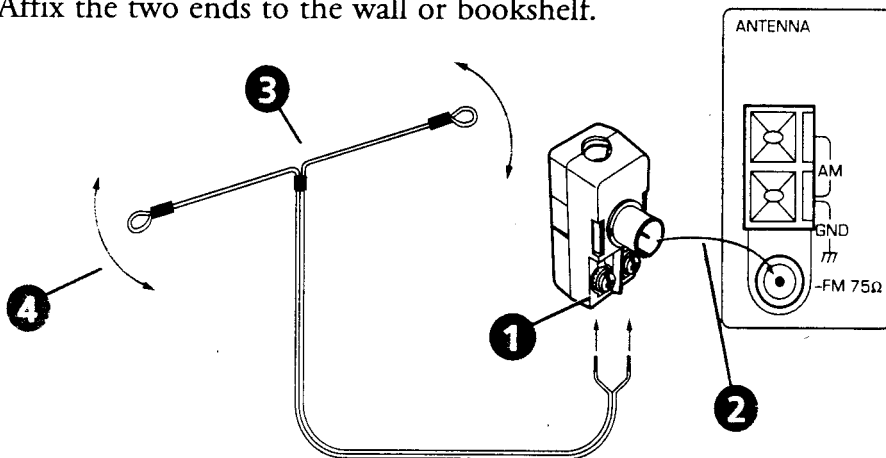

Using an FM outdoor antenna

For the best reception, install an FM outdoor antenna. Use a coaxial cable for the connection between the outdoor antenna and the FM antenna adaptor.

- 1 Prepare the cable:

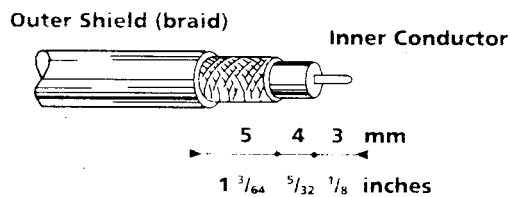

RG-6 (5C-2V) or RG-59 (3C-2V)

- 2 Open the antenna adaptor. Push the claws together (with your fingers) to release the lock and pull off the cover.

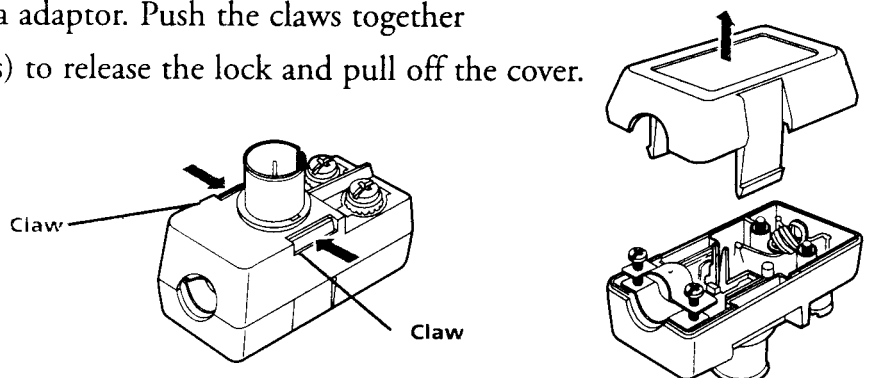

- 3** Using a Phillips screwdriver, loosen the screws holding the clamp in place, and insert the cable into the clamp.

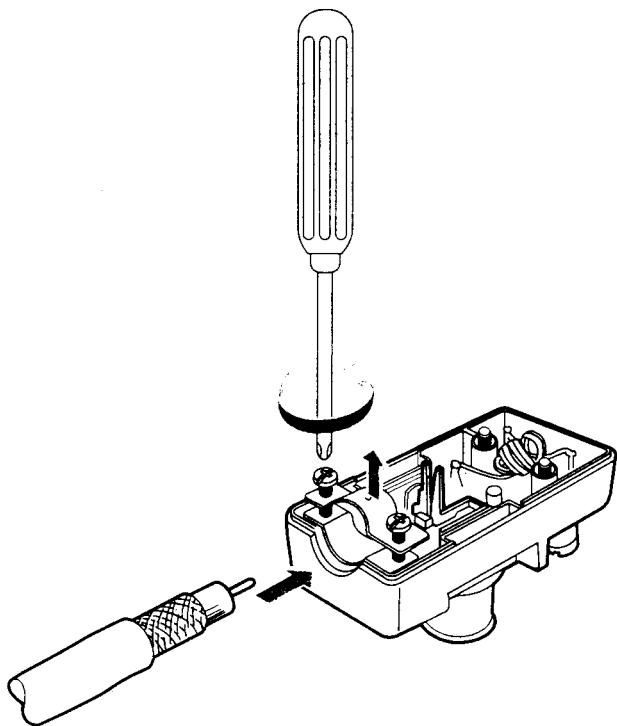

- 4** Make sure that the cable's braided insulation contacts the clamp, and that the inner conductor fits into the 'V' groove of the center pole.

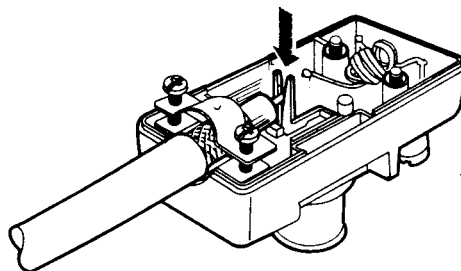

- 5** Tighten the clamp screws and replace the adaptor cover.

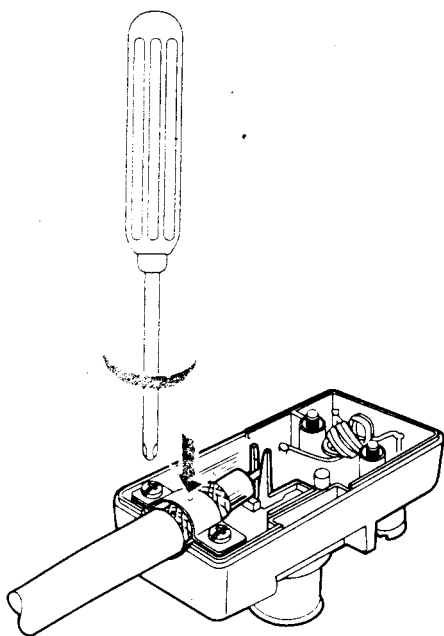

- 6** Connect the adapter to the Stage 3 Controller Antenna input.

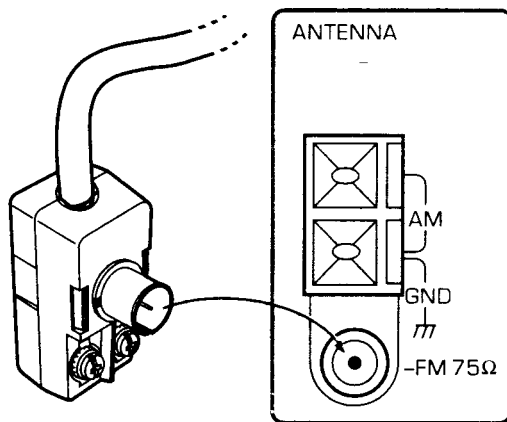

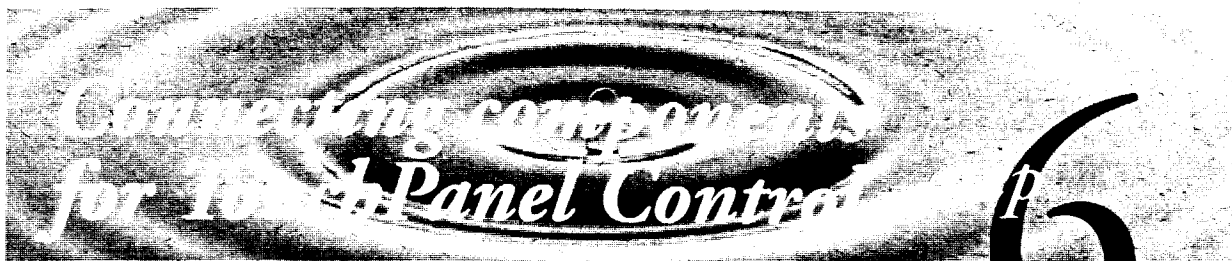

The TouchPanel can control most of the components in your home theater, whether they are made by Kenwood or by another manufacturer.

Connecting Kenwood components

Many Kenwood components use System Control connections to communicate with each other. Newer Kenwood products use SL16 jacks, while older ones use XS8 or XS jacks. The TouchPanel controls SL16-type components using System Control connections wired to the Stage 3 Controller. It controls other Kenwood components, including XS8 components using the Stage 3 Controller's IR repeater.

Before you connect your components, check the System Control jacks on the back of your Kenwood components to see if they are labeled 'SL16' or 'XS8(SL16)'.

About XS8 components

If you have a Kenwood XS8 cassette deck that is not IR-controllable and are using NO SL16 Kenwood source components with the Stage 3 Controller, you can set up the tape deck for XS8 System Control. Connect it to the Tape 1 inputs and follow the instructions on the next page as if it were an SL16 component. (This is the only situation in which an XS8 component can be controlled by the TouchPanel.)

Kenwood SL16-type components

- 1 If any component is labeled 'XS8/(SL16)', read its owner's manual and set it to the SL16 setting.
- 2 Connect these components as shown below. Be sure to push the plugs all the way in.

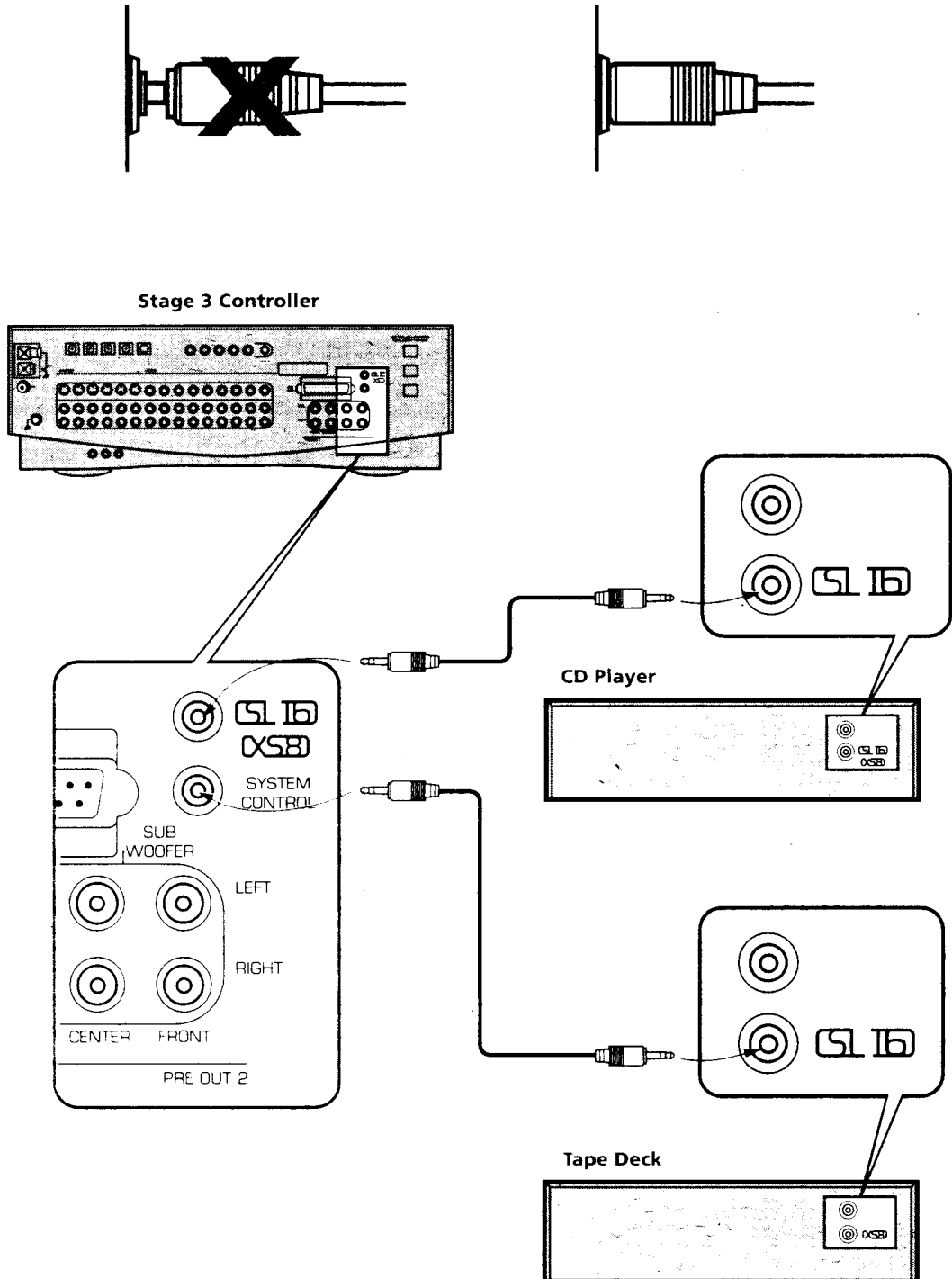

- 3 Read page 51 to set up the TouchPanel to control these components.

Other components

The Stage 3 Controller can control any component that has its own wireless remote (whether Kenwood or not). In a few instances, a component that does not have its own wireless remote may still work (read the component's owner's manual for more information). Most components that don't have a wireless remote cannot be controlled by the TouchPanel.

- 1 Plug the IR repeater into one of the Stage 3 Controller's Repeater jacks 1, 2, or 3.

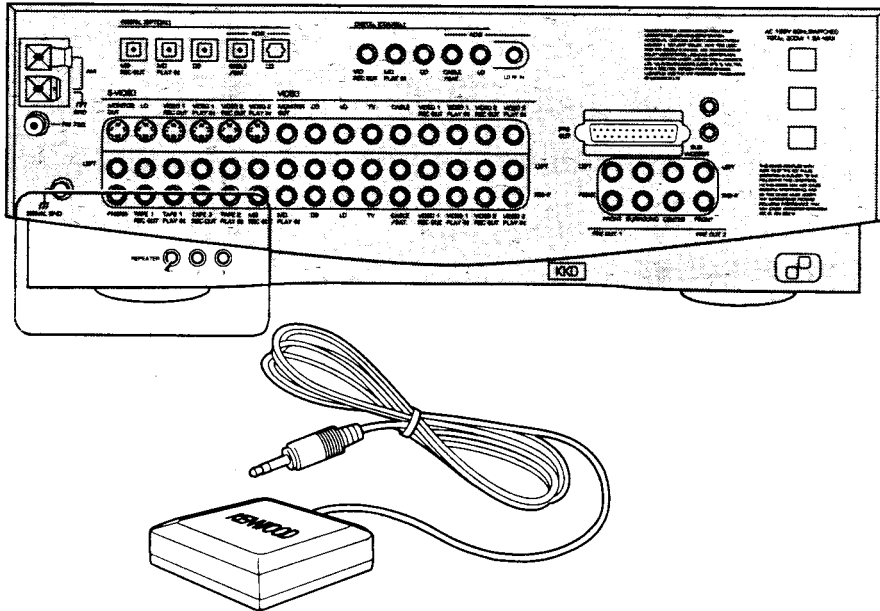

- 2 Using a small piece of Scotch tape or masking tape, temporarily mount the repeater on a surface near your components (make sure the tape does not cover the top or sides of the repeater).
- The repeater's coverage pattern is very broad, so its location in the room isn't critical. However, in rare cases you may have to experiment to find a location that works with all of your components.

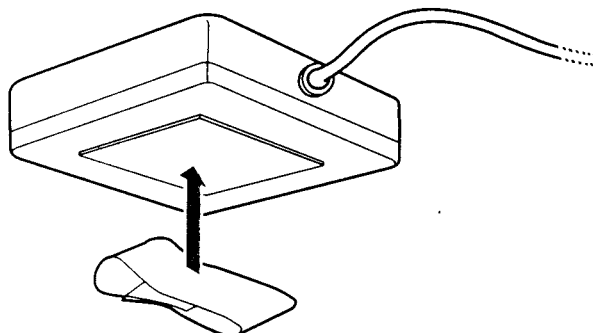

- 3 Continue through this guide until your components are set up and operating.
- 4 Later, when you are sure that the TouchPanel operates all of your IR-controllable components and accessories, peel the backing off of the double-stick tape on the the repeater and mount it.

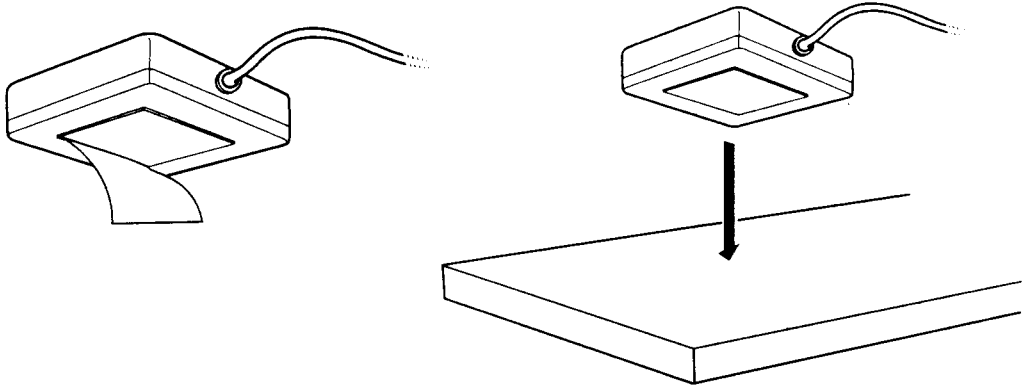

Controlling accessories

The TouchPanel can be used to control up to 36 accessories (such as lights, motorized projection screens, and so on) in conjunction with computerized home automation systems. Since the TouchPanel communicates with the home automation system using its IR repeater, make sure that the repeater is properly connected (read the section above) before setting-up the TouchPanel to control the accessories. Read *Using your Stage 3 Controller* to learn how to control accessories.

Turning the power on for the first time

Step

7

- 1 Check that all of the connections have been made properly.
- 2 Plug the power cord into an AC wall outlet.
- 3 Push the Main Power button on the lower left corner of the front panel.

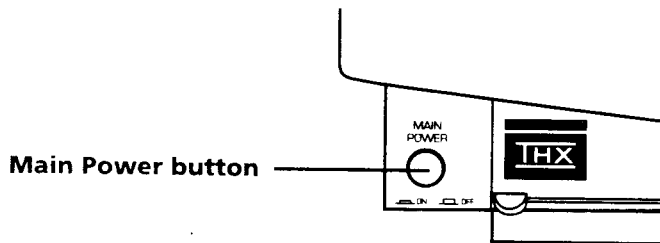

- 4 Touch the Remote Power button on the front panel.

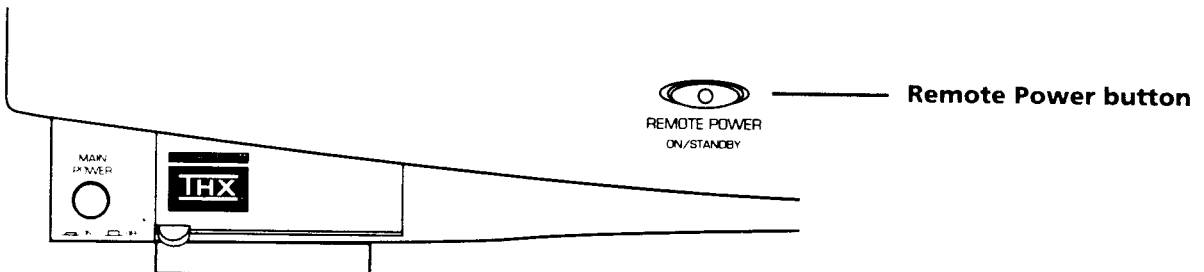

- 5 When you are done Using your Stage 3 Controller, do not turn the Main Power button off. Doing so will shut off the battery charge compartment.

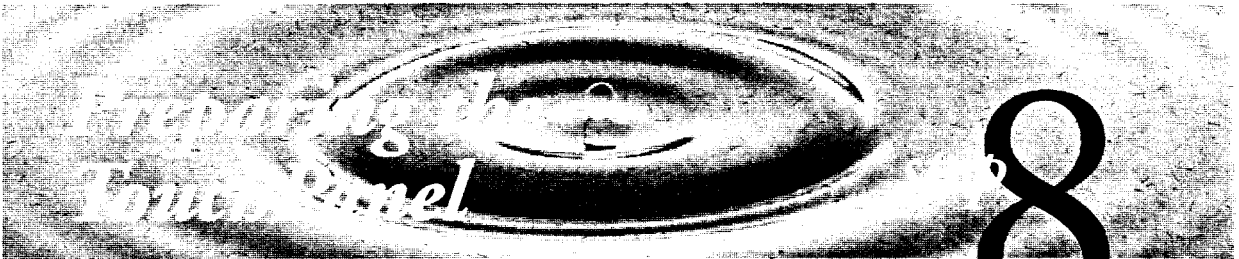

The TouchPanel can operate the Stage 3 Controller either remotely or while attached to its Dock on the front panel.

- Be sure to keep the metal contacts on the Dock and TouchPanel clean. Dirty contacts may interfere with operation of the TouchPanel while it is attached to the Dock.

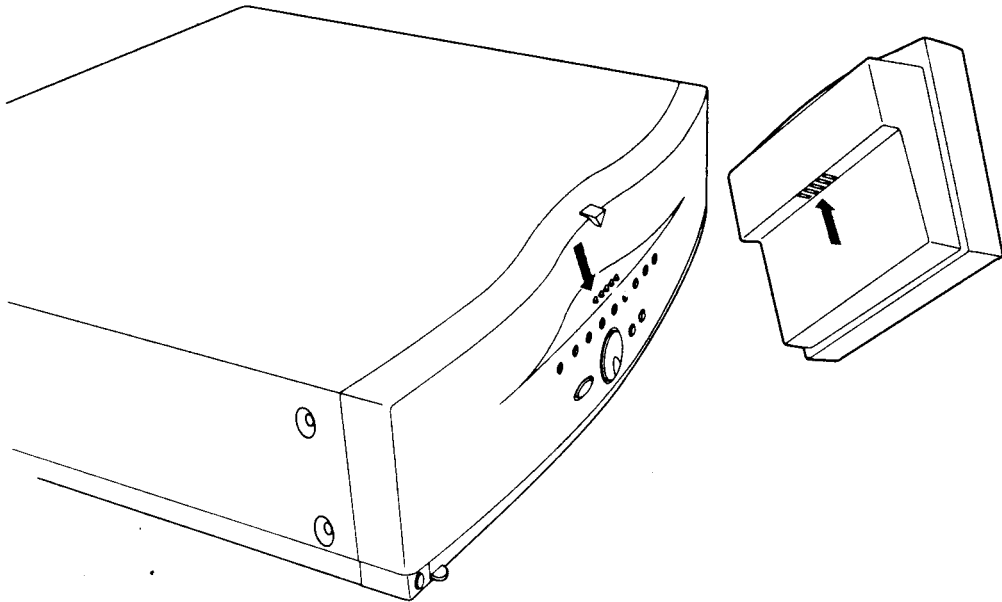

About the TouchPanel

The TouchPanel is a precision-engineered device, and should be handled carefully. Do not drop the TouchPanel or its rechargeable batteries onto a hard surface.

Installing the battery in the TouchPanel

- 1 Remove the battery compartment door by pressing down on the ridged area and sliding it off in the direction of the Arrow.

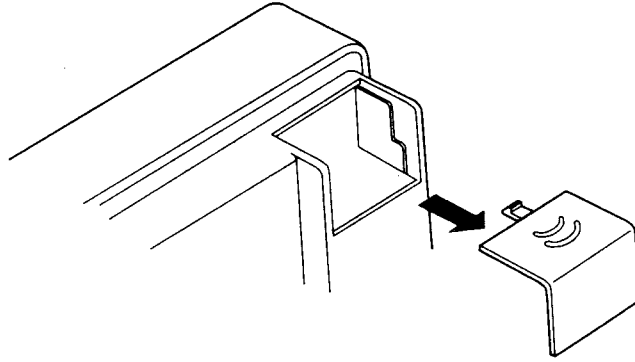

- 2 Insert the end of the battery with the contacts into the battery compartment, with the contacts facing up (towards the screen side of the TouchPanel) until it clicks into place.

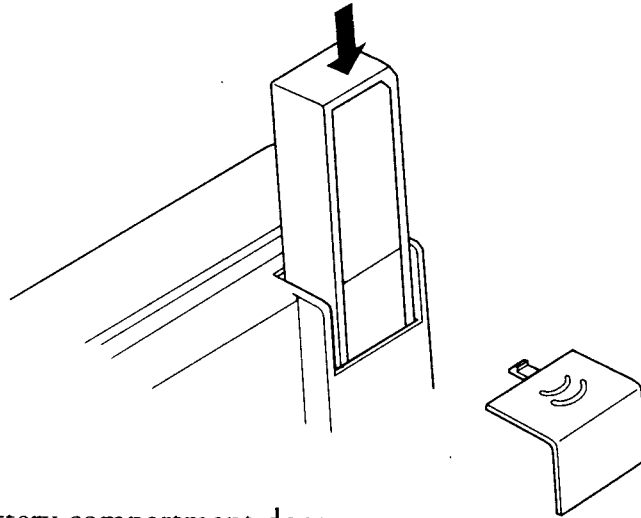

- 3 Replace the battery compartment door.

This battery should be sufficiently charged to finish setting up the system. If the low battery indicator lights while you're setting up the system, replace the battery with the fully charged one from the charging compartment. If that battery is not fully charged (the Battery Indicator is red), you have two options:

Option 1: Remove the low battery from the TouchPanel and perform the rest of the setup with the TouchPanel docked to the Controller (do not dock the TouchPanel with a low battery installed in it).

Option 2: Wait until the battery in the charging compartment is fully charged (the Battery Indicator light is green) and install it in the TouchPanel.

Attaching the TouchPanel to the Dock

- 1 Hold the TouchPanel with its top toward the Dock.

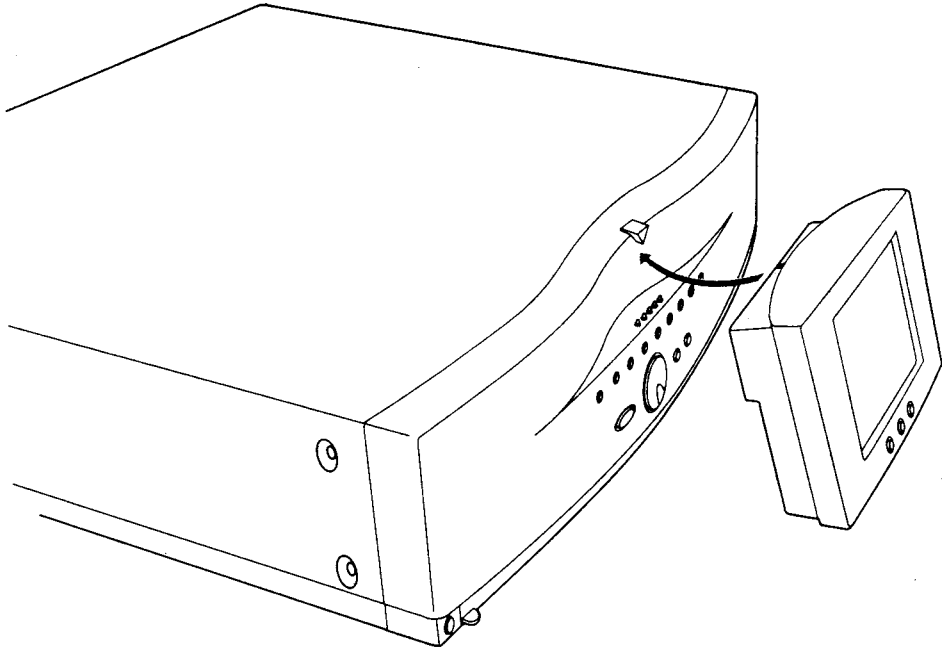

- 2 Insert the TouchPanel onto the Dock so that the TouchPanel lock is inside the slot on top of the TouchPanel

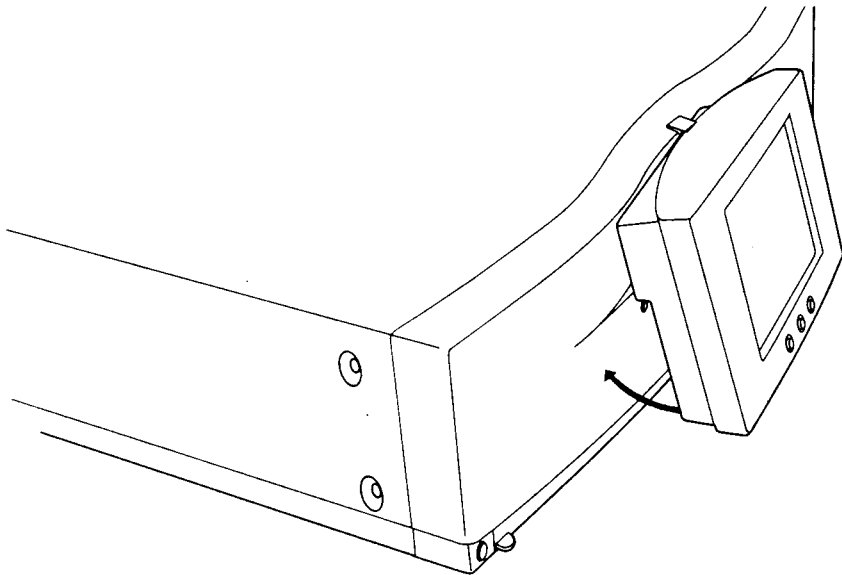

- 3 Gently push the bottom of the TouchPanel against the controller until it locks in place.

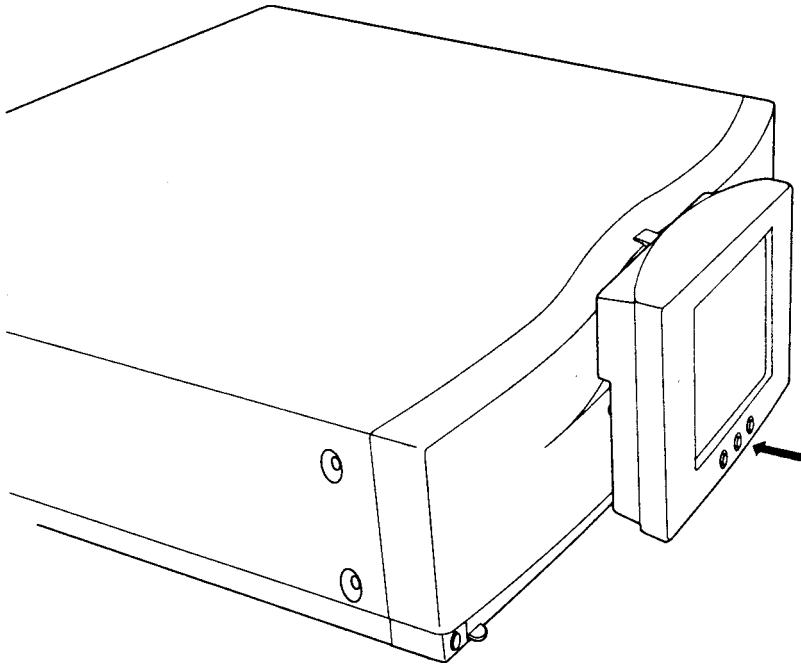

- To remove the TouchPanel from the Dock, reverse the above steps.
- The Stage 3 Controller unit will maintain the TouchPanel battery's charge level whenever the TouchPanel is attached to the Dock.
- Do not dock the TouchPanel if its battery is low. (displaying the low battery warning); this may diminish battery life. Instead, remove the battery from the TouchPanel and exchange it with the fully charged battery in the charge compartment before docking the TouchPanel.

Charging a battery

The Stage 3 Controller has a charging compartment for the extra battery. If the battery in the TouchPanel runs down, you can swap it with the extra battery and continue to use the TouchPanel to control the system.

- 1 Open the Battery Compartment door by sliding it up.
- 2 Insert the end of the extra battery into the Battery Compartment, with the contacts facing up until it locks into place.
- 3 The battery light next to the door will glow green momentarily, then will glow red.
- 4 Close the Battery Compartment door.

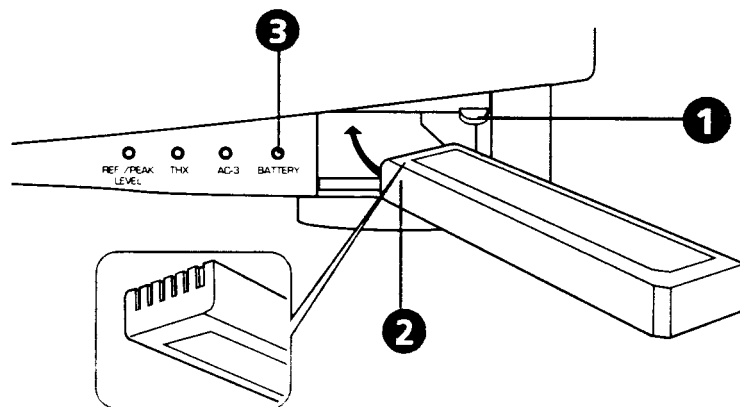

The battery will fully charge in 2-4 hours.

- The Battery Light will change to green when the battery has been fully charged.
- Since the compartment will keep the battery fully charged, we recommend that you leave the extra battery in the charger compartment until it is needed.

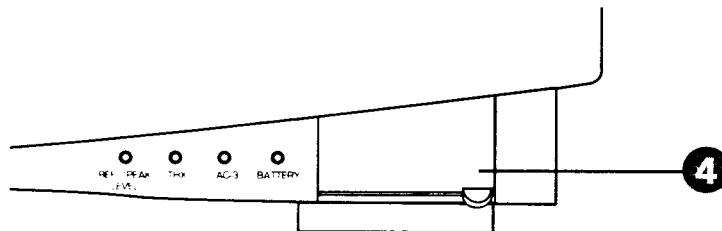

The TouchPanel screen will display the following message when its battery needs recharging:

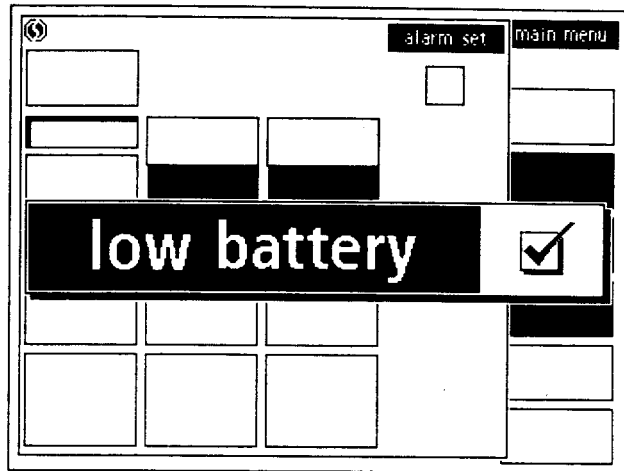

- Exchange the battery with the fully-charged extra battery in the controller's Battery Compartment.

About battery life

Under constant use (with the LCD display constantly lit), a fully-charged battery will last 4 to 5 hours before it needs to be recharged. Under normal use (the LCD display set to shut off a few seconds after it's used), the battery should last much longer. See "Setting the LCD Sleep Time" for instructions on adjusting the TouchPanel to help maximize battery life.

- The batteries can be recharged and reused approximately 250 times. You will know a battery is nearing the end of its life when its use time shortens.
- Only use DURACELL DR-17 batteries.

About the rechargeable batteries

- When batteries need recharging, recharge them as soon as possible. Also, do not expose the batteries to high temperatures. This will help the batteries maintain their charge.
- For more information about batteries, contact Duracell directly at 800-551-2355.

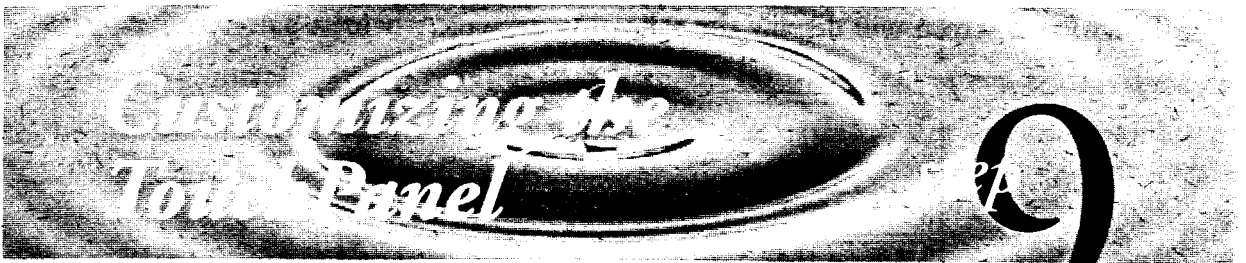

When you put the battery in for the first time, the TouchPanel displays the Touch The Target screen. This screen helps calibrate the TouchPanel so it can detect the exact center of each button.

Calibrating the TouchPanel

Touch the center of each target as it moves around the screen. You will touch the target 4 times. If you're not satisfied with the result, or you missed one of the targets, you can always start over from the Touch Screen button. (See page 61 of *Using your KC-Z1 Controller*).

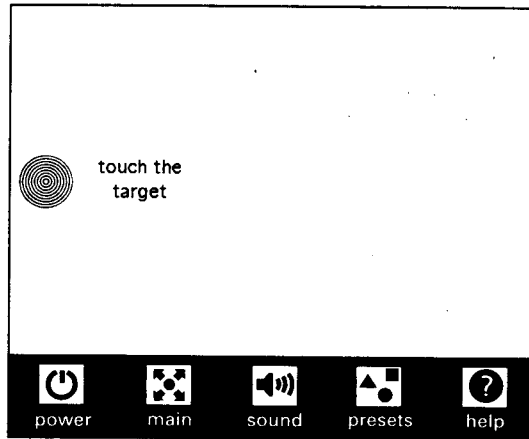

About the main menu

After you are finished calibrating the TouchPanel, the system displays the Stage 3 Title Screen for a short time, then the Main Menu screen.

SYSTEM COMPONENT ICONS

Lets you select and control your system components. Once you have set-up the TouchPanel, the Main Menu will show a separate icon for each component in your system.

RF COMMUNICATIONS ICON

Appears on every TouchPanel screen.

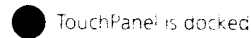

TouchPanel is docked



TouchPanel is receiving communication



TouchPanel is not receiving communication

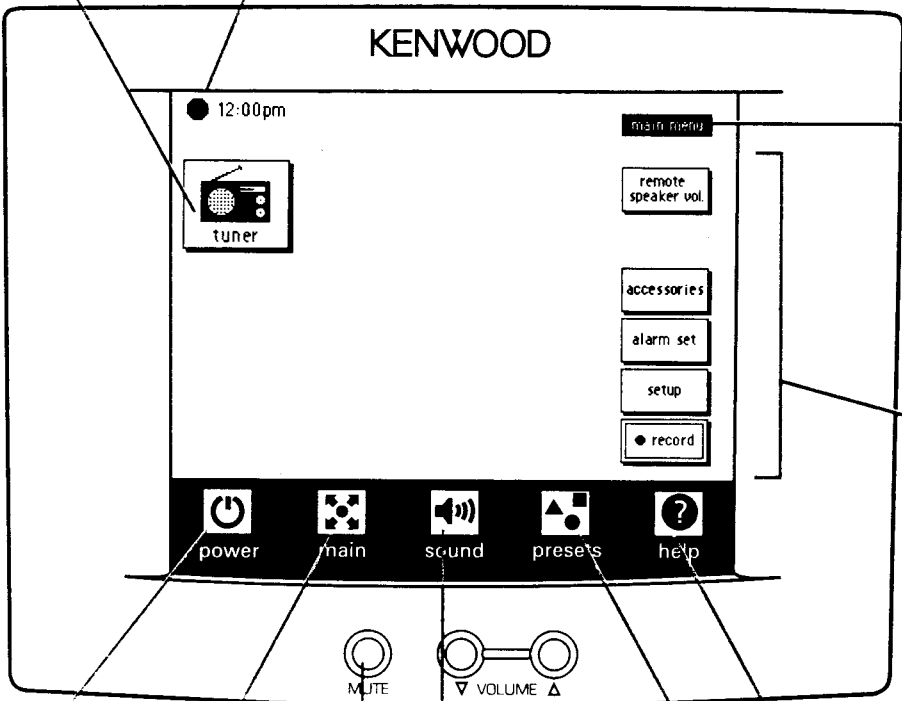

SCREEN NAME

Corresponds to the button you touched to activate the current screen.

SELECTION BUTTONS

Allow you to activate or adjust different functions.

POWER

MAIN

SOUND

allows you to control over the way you listen to sound.

VOLUME CONTROL AND MUTE BUTTONS

The TouchPanel's volume and mute buttons are always available no matter which screen you are on.

HELP

Gives you quick information on how the TouchPanel buttons work on the different screens.

PRESETS

Enables you to save any changes you make with the touch buttons (and more) as system presets for instant recall.

About the auto-off feature

The TouchPanel turns itself off after a period of time if it hasn't been used. This feature saves battery power, and can be adjusted (see page 48). To reactivate the TouchPanel, simply touch it again.

Changing the LCD contrast

Lighting conditions can affect your view of the TouchPanel screen. With this feature you can adjust the contrast for the best possible view.

- 1 To get to the LCD Contrast screen, touch these buttons:

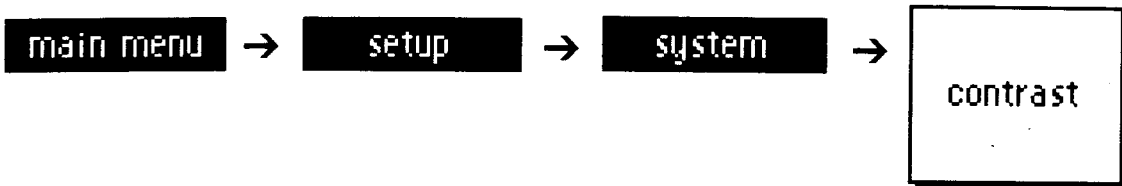

- 2 Adjust the contrast using the Arrow buttons.
- 3 Touch the CHECK-MARK to save your changes.

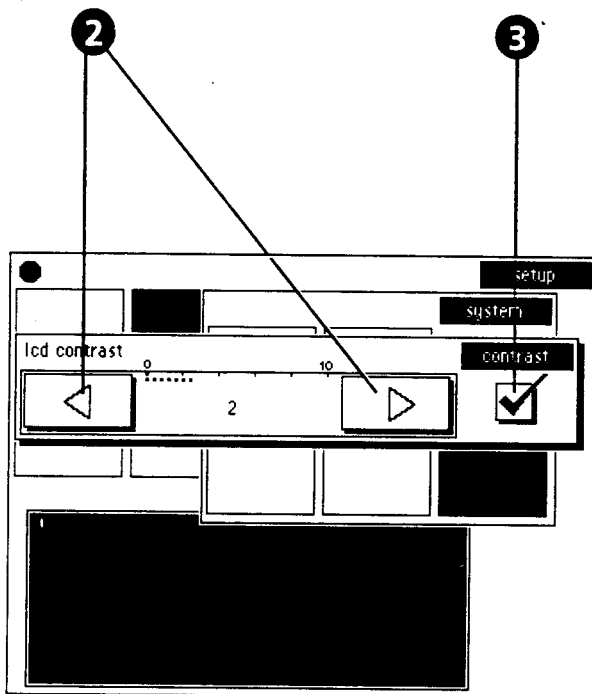

Creating a security code (optional)

You can set up a security code to restrict access to the Stage 3 Controller's set-up functions and default values. With a security code, the TouchPanel requests a 4-digit number before you can change any system, component, speaker, or DSP Logic default settings. You don't need to know the security code to operate all of the Stage 3 Controller's features. You can still make temporary changes through the Sound menu and even save those changes as a system preset (a way to save temporary system changes for future use).

1 To get to the Security screen, touch these buttons:

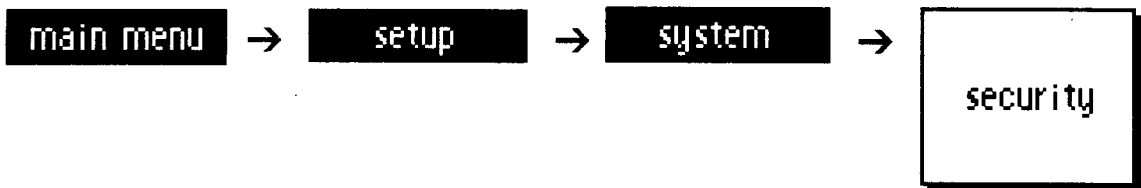

2 Touch YES on the Confirm screen. The TouchPanel displays the calculator pad.

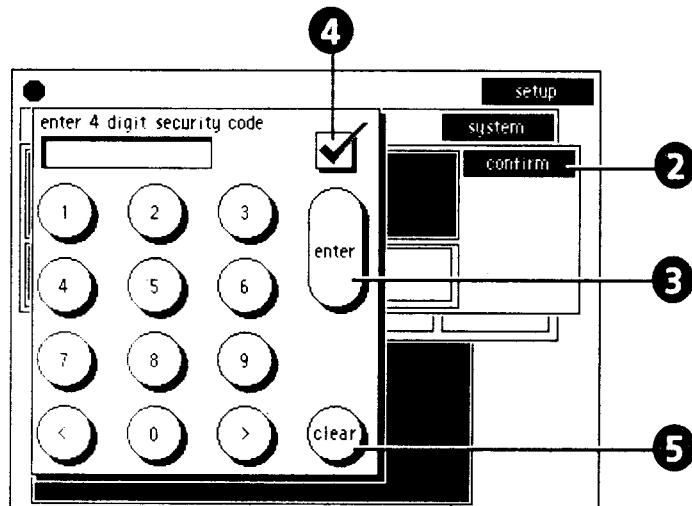

3 Enter a four-character security code and touch the ENTER key.

4 Touch the CHECK-MARK to save the security code.
No change is made if you use the CHECK-MARK before the ENTER key.

To turn off the security code

1 To turn off the security code, touch these buttons:

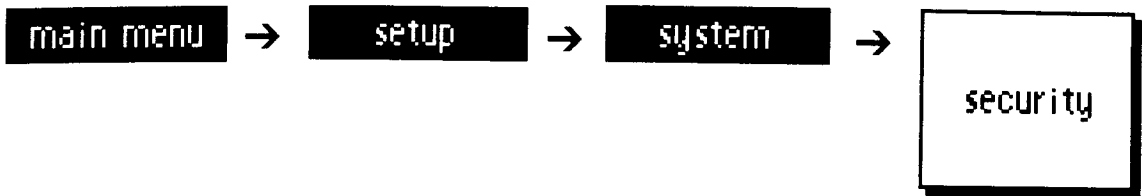

(You'll have to enter your security code at the Setup screen.)

2 Touch NO on the Confirm screen to turn off the security code..

If you forget your security code

If you forget the security code, you can re-set it. Hold down the MUTE button and press the RESET button on the back of the TouchPanel case with a paper-clip or other pointed object. You can set another security code after re-calibrating the screen.

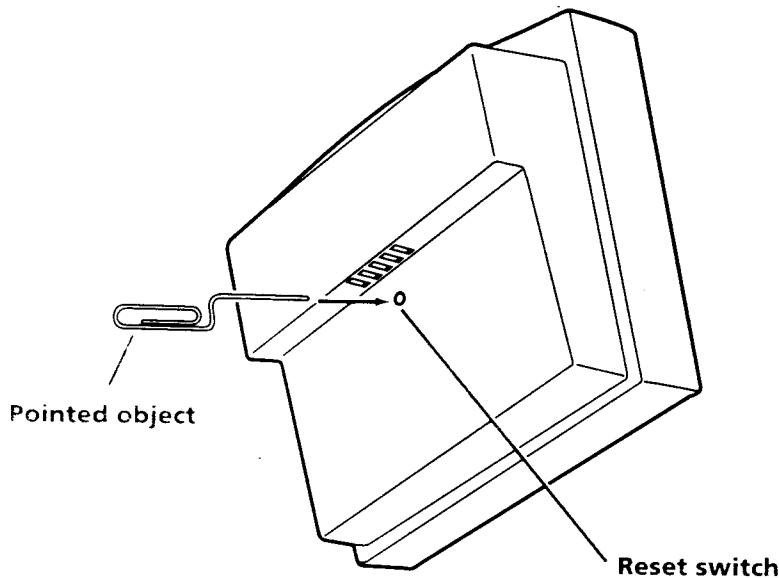

Setting the LCD screen saver

You can set the TouchPanel so that its screen turns off after it hasn't been used for a certain period of time. This helps conserve battery life. You can also determine how often the Stage 3 Controller updates the TouchPanel about the system's status. Setting a longer update interval also helps conserve battery life, but means that the TouchPanel may not read-out the system's current status when it first wakes-up. You determine the specific time intervals with the Sleep Time feature.

1 To get to the Sleep Time screen, touch these buttons:

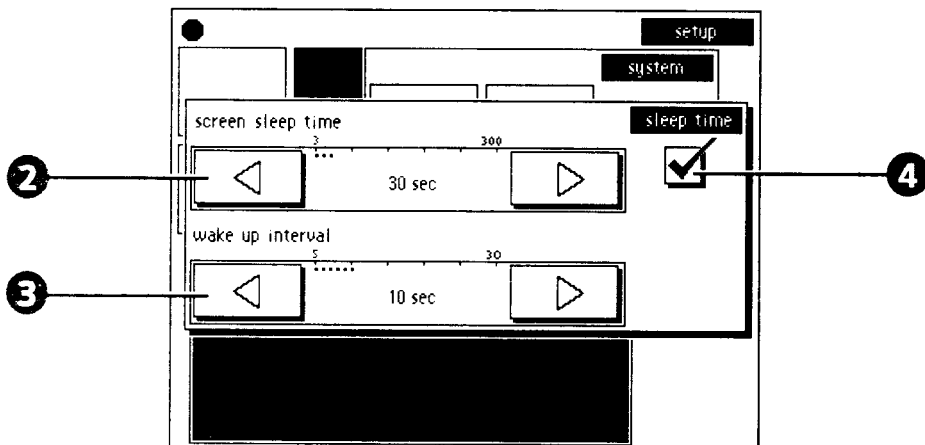
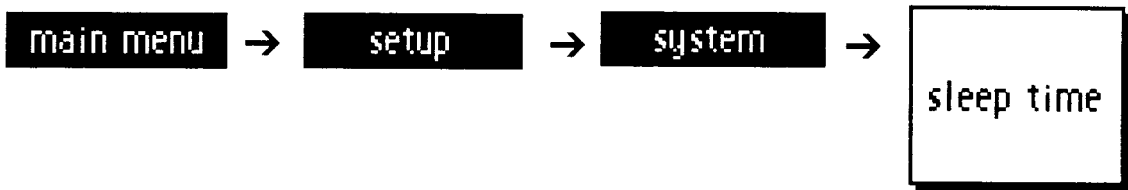

- 2** Use the Arrow buttons to change the screen sleep time (the time it takes the TouchPanel to turn-off after its last use).
- 3** Use the Arrow buttons to change the wake up interval (how often the Stage 3 Controller updates the TouchPanel about the system's current status).
- 4** Press the CHECK-MARK to save the changes.

Changing the communication channel

It isn't likely, but if the TouchPanel is having trouble communicating with the controller, you can change the communication channel. (See 'Troubleshooting' in *Using your Stage 3 Controller* for help with communication problems).

- 1 Connect the TouchPanel to its Dock on the controller.
- 2 To get to the System screen, touch these buttons:

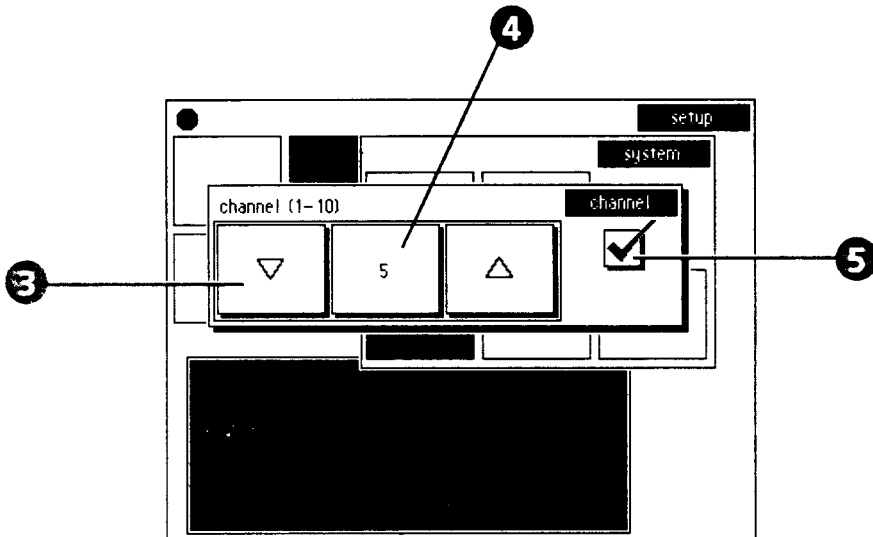
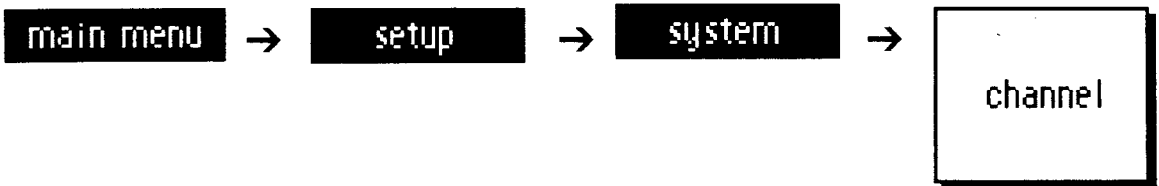

- 3 Use the Arrow buttons to change the channel number. You can choose any number between 1 and 10. Make sure it's different than the one currently displayed on the NUMBER (#) button.
- 4 If you want, you can touch the NUMBER button to use the calculator pad to change the channel number.
- 5 Touch the CHECK-MARK to save the settings.

Setting the time

The TouchPanel displays the time in the upper left corner of the Main Menu.

- 1 To get to the Time Set screen, touch these buttons:

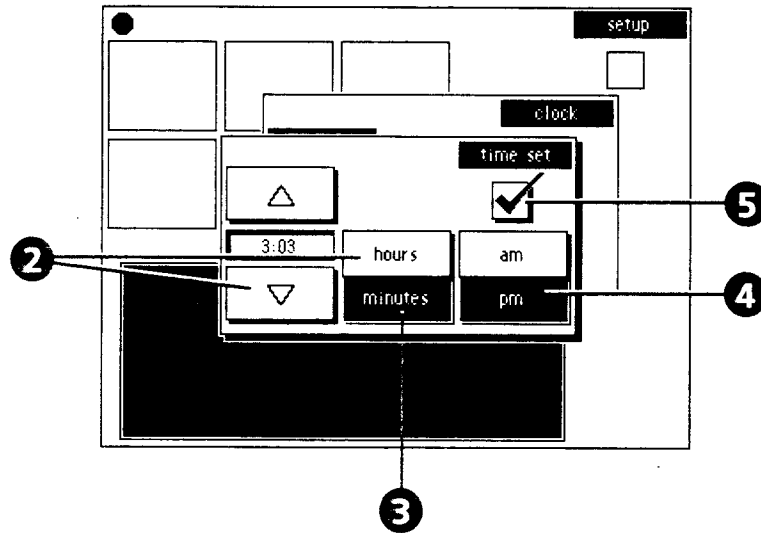
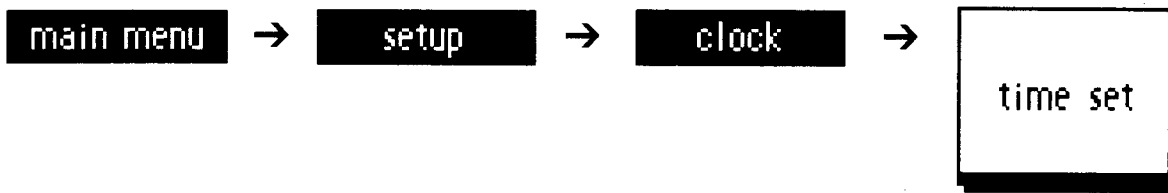

- 2 To change the hour, touch the HOURS button, then use the Arrow buttons to increase or decrease the time.
- 3 To change the minutes, touch the MINUTES button, then use the Arrow buttons to increase or decrease the time.
- 4 Touch the AM or PM buttons to set the time of day.
- 5 Touch the CHECK-MARK to save the changes.

NOTE: If power to the Controller is interrupted, or if you turn off the main power switch, you must reset the correct time.

Setting up audio and video components

10 step

In this step, you'll prepare the Stage 3 Controller to work with the different components in your system. Once set up, each component will have its own icon on the Main Menu.

If you've set up a security code, the TouchPanel displays the calculator pad and asks for your security code. See 'Creating a security code' on page 44 for more information.

Basic Procedure

Use the following basic procedure to set up each component in your system *except a DVD player*. To set up a DVD player follow the procedures on page 58.

1 To get to the Select Component screen, touch these buttons:



2 Touch the icon for the component you want to set up.
(For example, to set up a VCR connected to the Video 1 input, touch the VIDEO 1 button.)

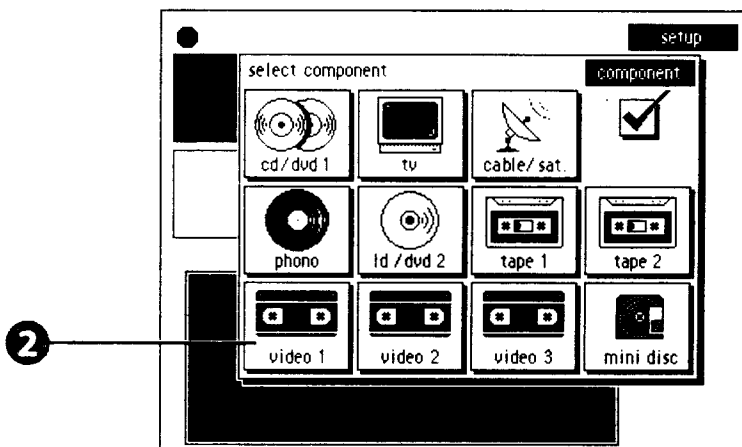

The TouchPanel displays the Features screen.

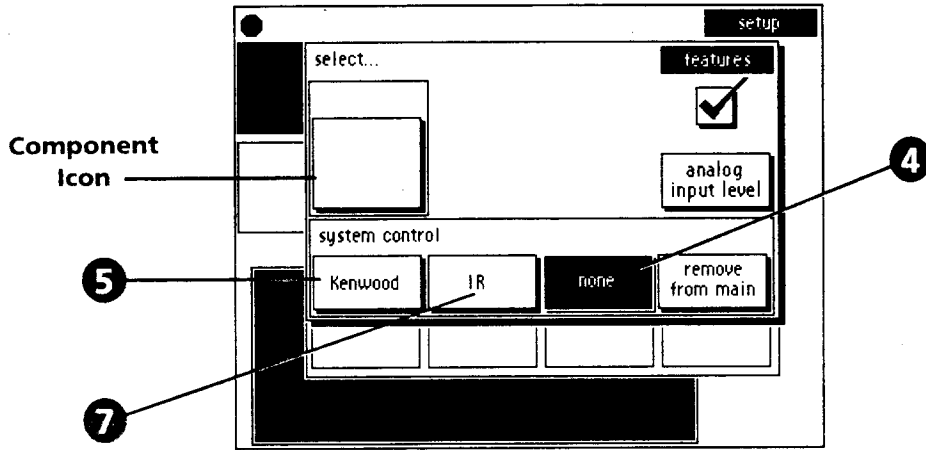

3 Select the system control mode following the instructions in steps 4, 5 and 6. If a button's outline is dotted, you cannot select it for that particular component.

4 If your component cannot be controlled remotely, select NONE. Then, look for the component in the sections below and continue with any additional steps there. (You're done with this section for that component.)

5 If you have a Kenwood SL16 component connected with system control cables, select KENWOOD. The TouchPanel displays the KENWOOD screen.

6 Touch the SL16 button, then look for the component in the sections below and perform any additional steps for that component. (You're done with this section for that component.)

NOTE: If you're setting-up a Kenwood XS8 cassette deck using System Control cables (see the note on page 31), touch the XS8 button, then look for that component in the sections below and perform any additional steps for that component.

7 If your component can be remotely controlled, select IR. Then continue with the 'Setting up IR codes' section below. (You're done with this section for that component)

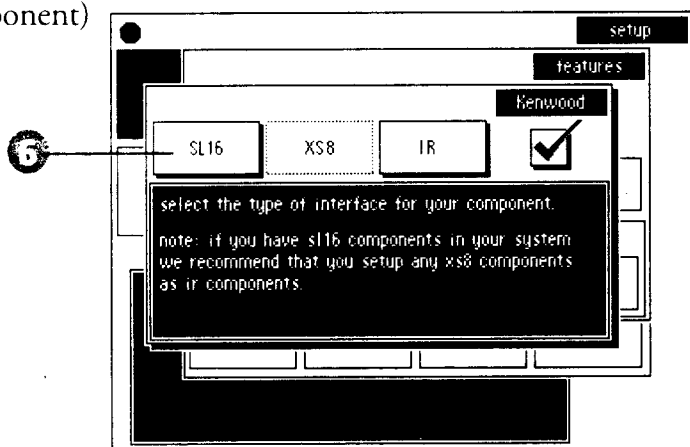

Setting up IR codes

- 1 After you select IR in the 'Basic set up' section above, the TouchPanel displays the IR Code screen.

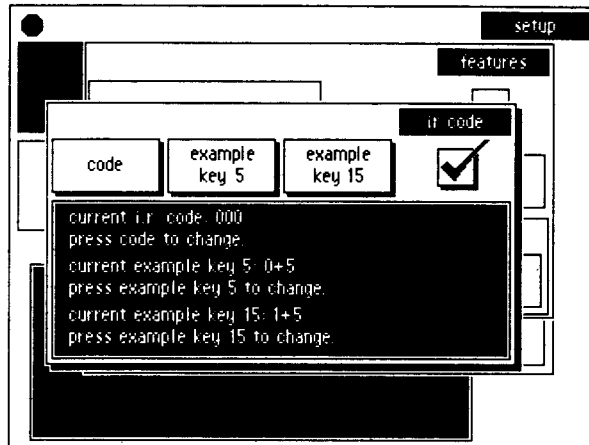

- 2 Touch the CODE button. The TouchPanel displays the calculator pad.

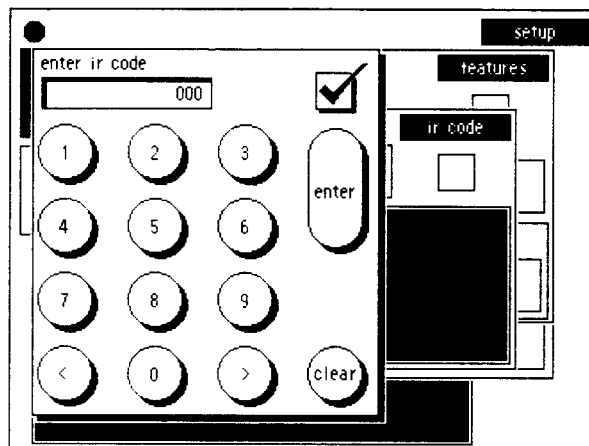

- 3 Look-up the 3-digit code number for your component on the list starting on page 70 and enter it with the calculator pad. Then touch the ENTER button.
 - 4 Touch the CHECK-MARK to save the IR code.
- If you're setting up a cassette deck, skip to step 14 below.

- 5 Touch the EXAMPLE KEY 5 button. The TouchPanel displays the Example 5 screen.

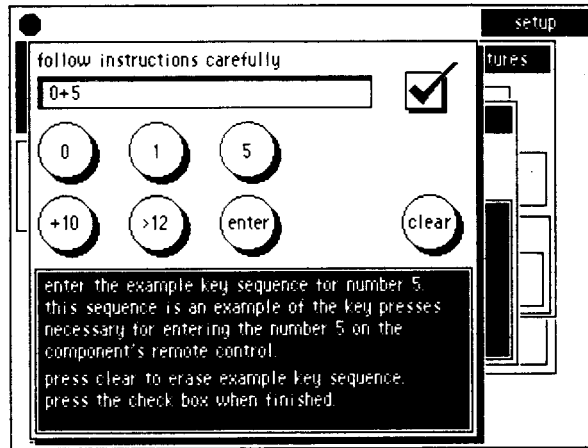

- 6 Touch the CLEAR button.

- 7 Using the buttons on the TouchPanel screen, press the button sequence you would press on your component's remote to enter the number 5. This may be "5" alone, or "0" plus "5" depending on your component. If you make a mistake, touch the clear button and try again. Then touch the CHECK-MARK.

- 8 Touch the EXAMPLE KEY 15 button. The TouchPanel displays the Example 15 screen.

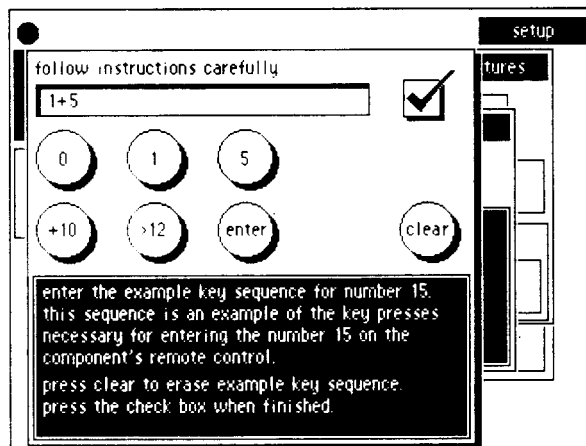

- 9 Touch the CLEAR button.

- 10 Using the buttons on the TouchPanel screen, press the button sequence you would press on your component's remote to enter the number 15. This may be "1" and "5" or "+10" and "5", depending on your component. If you make a mistake, touch the CLEAR button and try again. Then touch the CHECK-MARK.

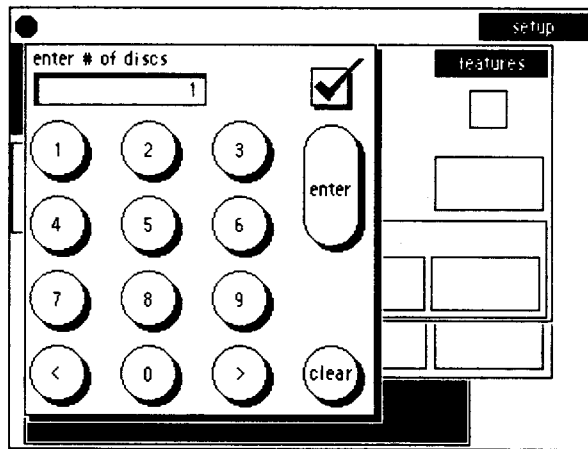

- 11 Touch the CHECK-MARK on the IR Code screen to return to the Setup screen.
- 12 Look for the component in the sections below and perform any additional steps for that component.

Setting up a CD player:

- 1 Finish the 'Basic setup procedures' section above.
- 2 Touch the # OF DISCS button. The TouchPanel displays the calculator pad.
- 3 Enter your CD player's disc capacity, then touch the ENTER button.
- 4 Touch the CHECK-MARK to save the number of discs, and return to the setup screen. (No change is made if you use the CHECK-MARK before the ENTER button.)

See *Using your Stage 3 Controller* to adjust the analog input level.

Setting-up a Cassette Deck

You can control 2 cassette decks with the Stage 3 Controller. Although the setup for both is almost identical, you'll need to set up each one individually.

- 1 Finish the 'Basic setup procedures' section above.
NOTE: If you're setting-up a Kenwood XS8 cassette deck connected using System Control cables (see the note on page 31), touch the XS8 button.
- 2 If the deck has a single well, touch the SINGLE button. If it has dual wells, touch the DUAL button.
- 3 If you want to configure the Tape-2 input as a tape monitor loop (for use with a 3-head deck, for example), touch the ENABLE TAPE-2 MONITOR button.
- 4 Touch the CHECK-MARK to save the settings and return to the Component setup screen.

See *Using your Stage 3 Controller* to adjust the analog input level.

Setting-up a laser disc player

If you have already completed the Basic Set Up Procedures section above, there are no additional steps. Touch the CHECK-MARK to return to the Component setup screen.

See *Using your Stage 3 Controller* to adjust the analog input level.

Setting-up a mini disc recorder

If you have already completed the Basic setup procedures section above, there are no additional steps. Touch the CHECK-MARK to return to the Component setup screen.

See *Using your Stage 3 Controller* to adjust the analog input level.

Setting-up a VCR

If you have already completed the Basic setup procedures section above, there are no additional steps. Touch the CHECK-MARK to return to the Component setup screen.

You can control up to 3 VCRs with the Stage 3 Controller. Although the setup for all 3 is identical, be sure you set up each one individually.

See *Using your Stage 3 Controller* to adjust the analog input level.

Setting-up a TV

If you have already completed the Basic Set Up Procedures section above, there are no additional steps. Touch the CHECK-MARK to return to the Component setup screen.

See *Using your Stage 3 Controller* to adjust the analog input level.

Setting-up a satellite receiver or cable TV tuner

If you have already completed the Basic setup procedures section above, there are no additional steps. Touch the CHECK-MARK to return to the Component setup screen.

The Stage 3 Controller will recognize whether the IR code you entered is for a satellite tuner or a cable TV tuner and will automatically configure itself for whichever you are using.

See *Using your Stage 3 Controller* to adjust the analog input level.

Setting-up a turntable

No further setup is required. Touch the CHECK-MARK to return to the Component setup screen.

See *Using your Stage 3 Controller* to adjust the analog input level.

Setting up a DVD player

Setting up a DVD player to be controlled by the Stage 3 Controller is a little bit different than for other components, so follow these instructions carefully.

- 1 Touch these buttons to get to the Select Component screen:



- 2 If you have connected the DVD player to the CD input, touch the CD / DVD 1 button. If you have connected the DVD player to the laser disc input, touch the LASER DISC / DVD 2 button. (The following setup procedure is the same for either input.)

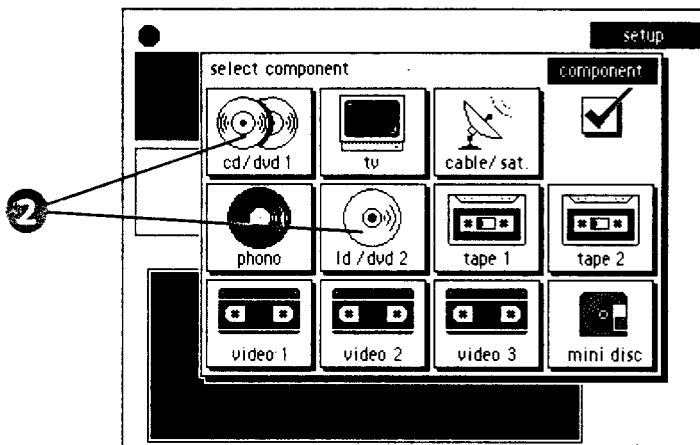

The TouchPanel displays the Features screen.

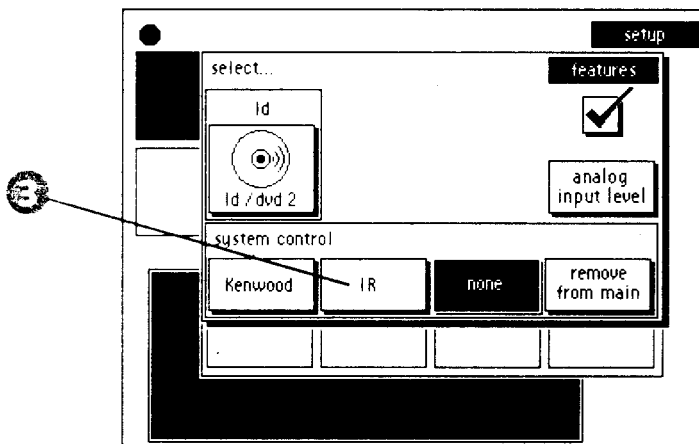

- 3 Select IR. The TouchPanel displays the IR Code screen.

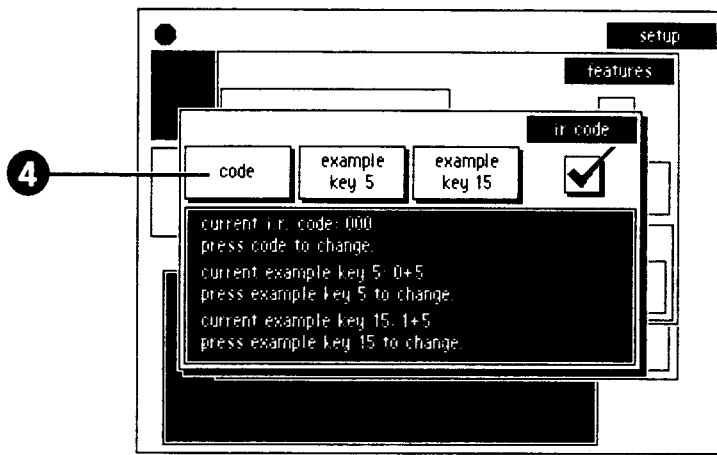

4 Touch the code button. The TouchPanel displays the calculator pad.

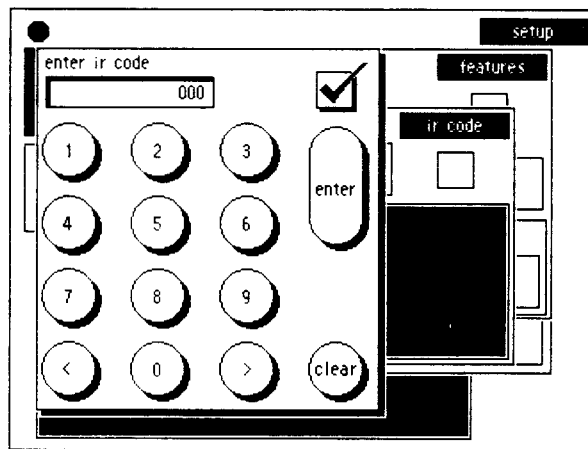

- 5** Look up the 3-digit code number for your DVD player on the list starting on page 74 and enter it with the calculator pad. Then touch the ENTER button.
- 6** Touch the CHECK-MARK to save the IR code.
- 7** Touch the EXAMPLE KEY 5 button. The TouchPanel displays the Example 5 screen.

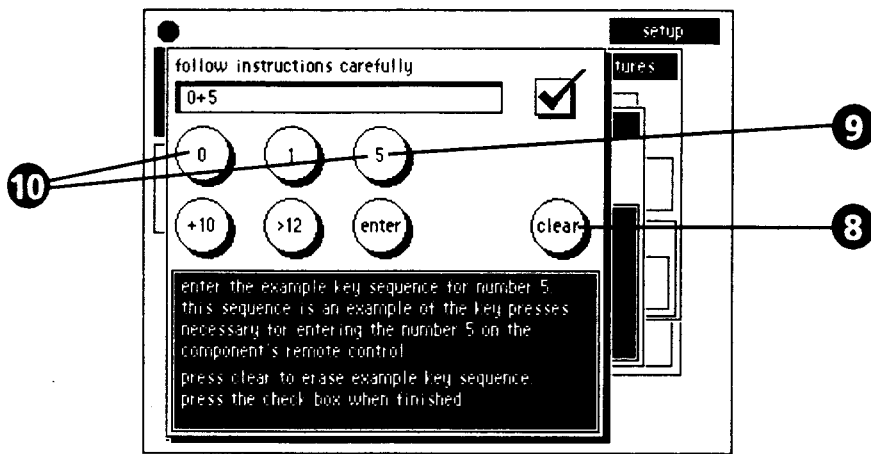

- 8 Touch the CLEAR button.
- 9 If your DVD player allows you to enter numbers directly (for example, to advance to track 5 you would enter “5”), touch the 5 key. If you make a mistake, touch the CLEAR button and try again. Then touch the CHECK-MARK.
- 10 If your DVD player requires that you use the “0” key to enter numbers below 10 (for example, to advance to track 5 you would enter “0”, then “5”), touch the “0” key and the “5” key. If you make a mistake, touch the CLEAR button and try again. Then touch the CHECK-MARK.
- 11 Touch the CHECK-MARK on the IR Code screen to return to the Setup screen.
- 12 Touch the EXAMPLE KEY 15 button. The TouchPanel displays the Example 15 screen.

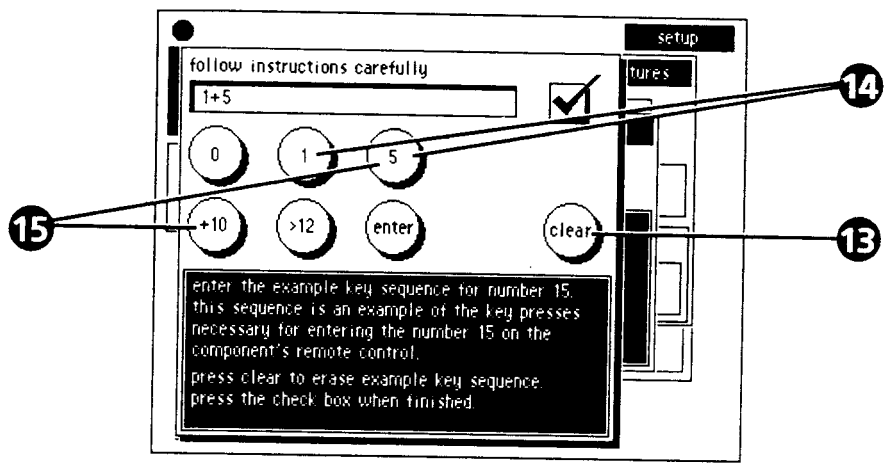

- 13 Touch the CLEAR button.
- 14 If your DVD player allows you to enter numbers directly (for example, to advance to track 15 you would enter “1” then “5”), touch the 1 key and the 5 key. If you make a mistake, touch the CLEAR button and try again. Then touch the CHECK-MARK. (This will allow direct input of numbers 1-999.)
- 15 If your DVD player requires that you use a “+10” key to enter numbers above 10 (for example, to advance to track 15 you would enter “+10”, then “5”), touch the “+10” key and the “5” key. If you make a mistake, touch the CLEAR button and try again. Then touch the CHECK-MARK. (This will allow direct input of numbers 1-99.)
- 16 Touch the CHECK-MARK on the IR Code screen to return to the Setup screen.

The Stage 3 Controller will recognize that the IR code you entered is for a DVD player and will automatically configure itself.

See *Using your Stage 3 Controller* to adjust the analog input level

NOTE: Some components provide for entering numbers both directly and by using a “+10” key. We recommend that you always set up such components according to the instructions in step 14.



In this step, you will tell the Stage 3 Controller what speakers you are using in your system and what sizes they are. This allows the Controller to send specific frequencies to the correct speakers. You will also adjust the Stage 3 Controller to prevent your speakers from being overdriven.

Speaker setup also lets you balance the levels of all the speakers in your system and adjust for the distance between each speaker and your listening position. Once the speaker levels in your system are all properly balanced and the distances adjusted for, the system will reproduce a much more convincing and realistic surround sound environment.

About default settings

The settings you make here will be your system's default settings. You can always change the settings while you're listening to the system (and save those settings as a system preset), but whenever your system is powered-down, the settings will return to those you establish here.

Setting up the front speakers

- 1 To get to the sound setup screen, touch these buttons:



The TouchPanel displays the Sound screen.

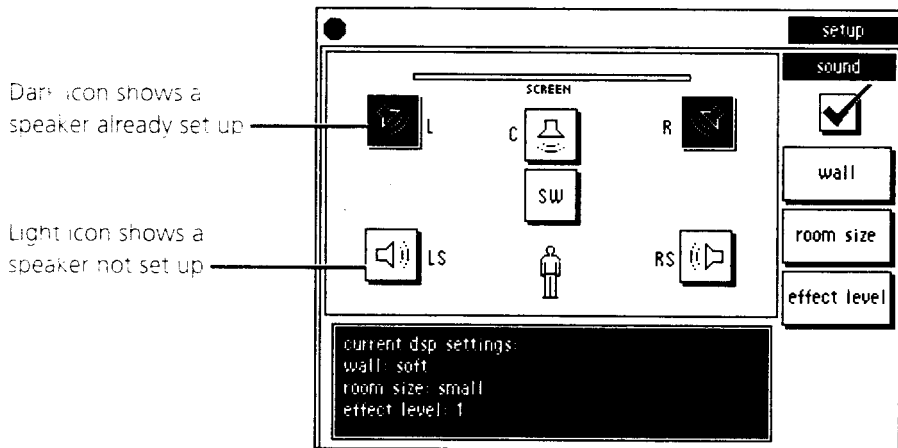

- 2 Touch the L speaker icon. The TouchPanel displays the Speaker screen.

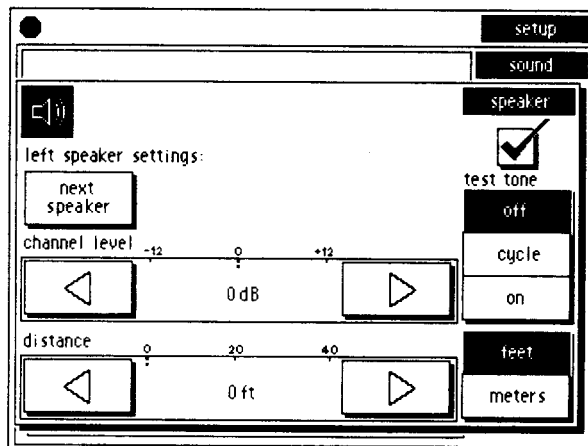

- 3 Measure the distance (in a straight line) between the left speaker and your listening position, and enter this distance with the DISTANCE Arrow buttons. You change the distance by 1 foot each time you touch an Arrow key.
- 4 Touch the CHECK-MARK to return to the Sound screen.
- 5 Repeat these steps for the right speaker.

Setting up the center and surround speakers

You must set the center and surround speaker settings even if you don't have these speakers in your system.

- 1 Touch the C speaker icon on the sound screen. The TouchPanel displays the Speaker screen.

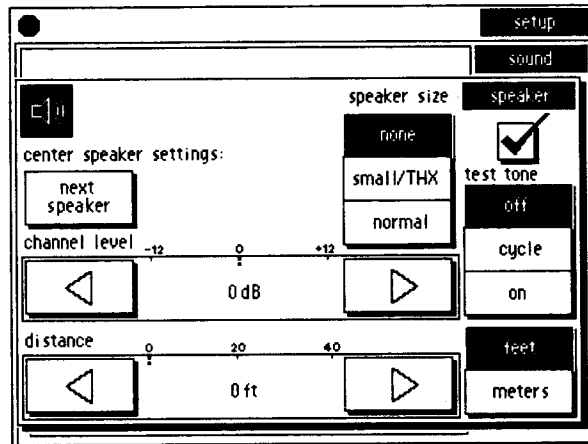

- 2 If you do not have a center speaker, touch the NONE button. If your center speaker is small, and not capable of reproducing deep bass, touch the SMALL button. If your center speaker is large, and capable of reproducing deep bass, touch the NORMAL button.
- 3 Measure the distance (in a straight line) between the center speaker and your listening position, and enter this distance with the DISTANCE Arrow buttons. You change the distance by 1 foot each time you touch an Arrow key.
- 4 Touch the CHECK-MARK to return to the Sound screen.
- 5 Repeat these steps for the left and right surround speakers.

Setting up the subwoofer

You must set the subwoofer settings even if you don't have one in your system.

- 1** Touch the SW speaker icon on the Sound screen.
- 2** If you do not have a subwoofer, touch the NONE button. Then touch the CHECK-MARK and skip ahead to the 'Balancing the speaker levels' section (Step 12).
- 3** If you have a subwoofer, touch the NORMAL button.
- 4** Measure the distance (in a straight line) between the subwoofer speaker and your listening position, and enter this distance with the DISTANCE Arrow buttons. You change the distance by 1 foot each time you touch an Arrow key.
- 5** Touch the CHECK-MARK to return to the Sound screen.

Setting the bass limiter

Film soundtracks and other programs recorded in Dolby Digital (AC-3) can contain enough bass energy to damage some speakers. The Stage 3 Controller has a bass limiter circuit that keeps the output to your speaker within safe limits.

- 1 To get to the Sound screen (not the same as in the previous steps), touch this button:



The TouchPanel displays the main Sound screen:

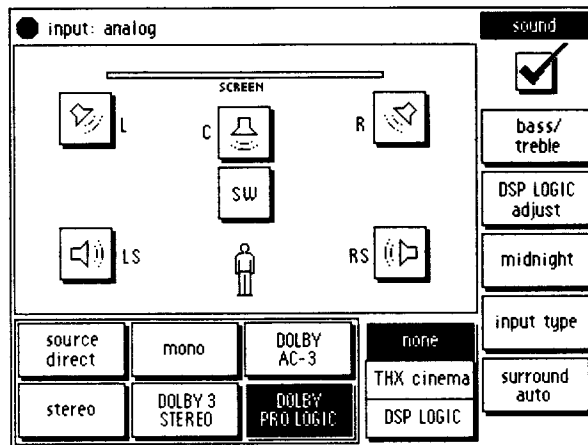

- 2 If your system has a subwoofer, touch the SW speaker icon. If it does not have a subwoofer, touch either the L or R speaker icon. The TouchPanel displays the Speaker screen.

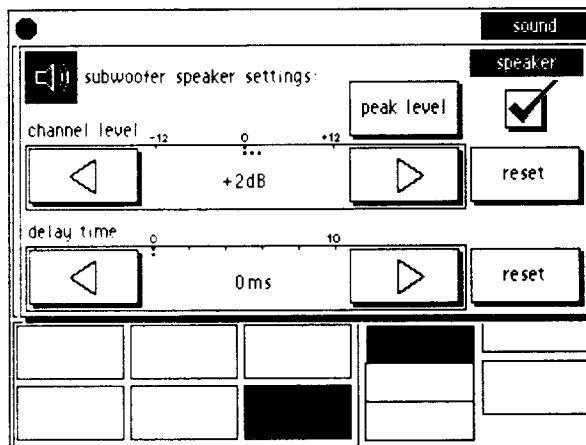

3 Touch the PEAK LEVEL button. The TouchPanel displays the Bass Peak screen.

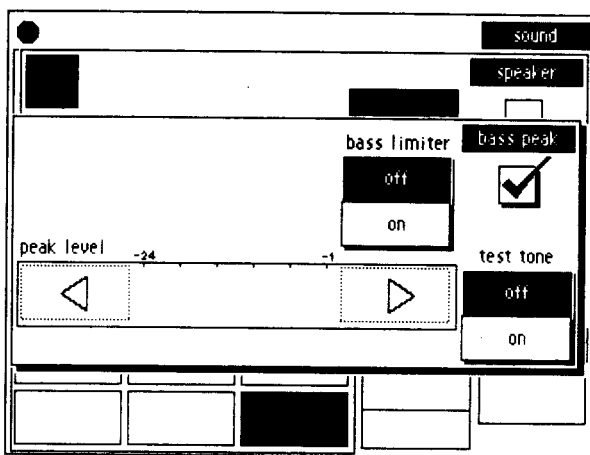

- 4** Touch the TEST TONE ON button. You will hear test noise. (The Controller's volume automatically changes to 0 dB when the test noise is on.)
- 5** Use the right PEAK LEVEL arrow button to slowly increase the speaker volume until you begin to hear audible distress from the woofer (distortion, clicking, "bottoming"). Leave the peak level volume at this level.
- 6** Touch the BASS LIMITER ON button.
- 7** Touch the CHECK-MARK to return to the Speaker screen, then touch the CHECK-MARK ON that screen to return to the Sound screen. The bass limiter has been automatically adjusted to prevent your speakers from being overdriven.



Balancing the speaker sound levels

12

You can balance the speakers by ear, or you can use a sound level meter. Using a sound level meter lets you balance your system more accurately, and lets you set the reference playback level. (Once the reference level is set, carefully-transferred films will play at the volume levels intended by their makers when the Stage 3 Controller's volume is set to 0dB. You can, of course, still set the volume level to your own preferences). Once you have balanced the speaker levels, you can also make adjustments while listening to music or watching movies. (See *Using your Stage 3 Controller* for instructions).

Balancing the speaker levels by ear

- 1 To get to the Sound screen, touch these buttons:



The TouchPanel displays the Sound screen.

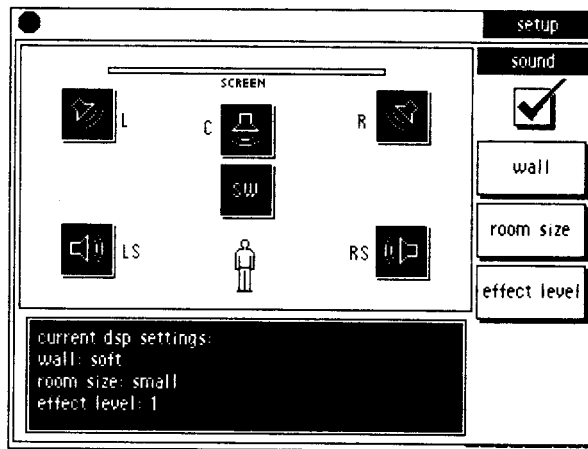

- 2 Touch the L speaker icon. The TouchPanel displays the Speaker screen.

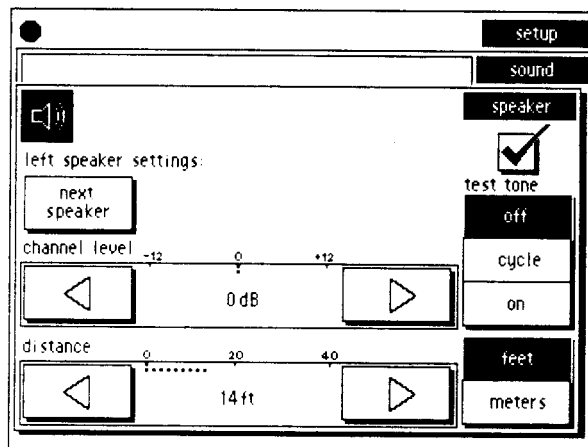

- 3 Touch the TEST TONE CYCLE button, and listen as the test noise cycles through each speaker in your system. (The Controller's volume automatically changes to 0dB when the test noise is on. If the noise is uncomfortably loud, use the TouchPanel VOLUME buttons to lower the volume to -6dB). Compare the levels of each channel.
- 4 If the left speaker is noticeably louder or quieter than the other channels, use the CHANNEL LEVEL Arrow buttons to match its level to the rest of the test noise cycle.

(If you want to hear the test noise play only through the left speaker, touch the TEST TONE ON button). You can adjust the speaker's level by 1 dB each time you touch a CHANNEL LEVEL Arrow button.

- 5 Touch the NEXT SPEAKER button to adjust the next speaker. and repeat steps 2–4 for each speaker in your system.
- 6 After you are done balancing each of the speakers, touch the CHECK-MARK to save the settings.

About balancing the subwoofer level

The test noise for the subwoofer is filtered, and doesn't sound as loud to the human ear as it really is. (It's designed to be used with a sound level meter to balance the channel levels). Therefore, to balance the subwoofer by ear, it is best to use familiar music or film soundtracks. This makes it easier to tell if the subwoofer is at the correct volume.

Balancing the speaker levels with a sound level meter

You can use a sound level meter to more accurately balance your system and set the reference playback level. These instructions assume you are using a Radio Shack SPL meter, model 33-2050.

To get to the Sound screen, touch these buttons:



Touch the L speaker icon. The TouchPanel displays the Speaker screen:

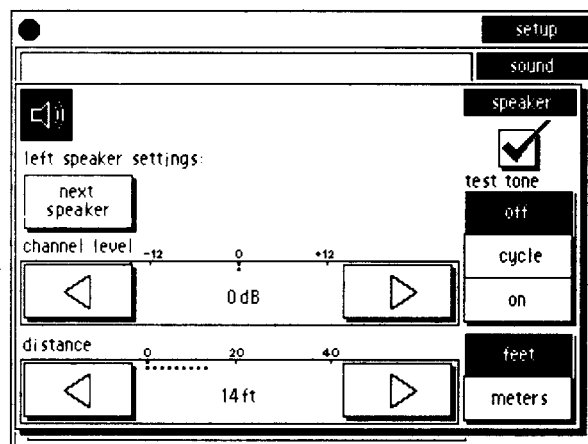

- 3** Eliminate as many external noise sources as possible.
- 4** Touch the TEST TONE ON button. (The Controller's master volume will automatically change to 0dB. Do not change the master volume setting until you have completed the speaker balancing procedure.)
- 5** On the SPL meter, choose 70dB on the large dial, and set the meter controls to 'C' and 'Slow' .
- 6** Sit at the main listening position. Hold the meter at arm's length, and at ear height. Use the channel level buttons to adjust the selected speaker's level so that the needle on the meter points between 4 and 6 (75 dB). You can adjust the speaker's level by 1 dB each time you touch a CHANNEL LEVEL Arrow button.
- 7** Touch the NEXT SPEAKER button to adjust the next speaker and repeat these steps for each speaker in your system.
- 8** After you are done balancing each of the speakers, touch the CHECK-MARK to save the settings.

DSP Logic combines Dolby Digital (AC-3) or Dolby Surround Pro Logic with Kenwood Digital Signal Processing. Using it, you can simulate the sound of different rooms, from an intimate club to a large theater. We recommend setting these default values while you are playing familiar music or movies, with DSP Logic activated, so you can hear how the adjustments affect the sound.

Experiment to create the surround sound that best suits the music and films you play.

To get to the Sound screen, touch these buttons:



Changes the simulated wall texture, or resets it to its default value.

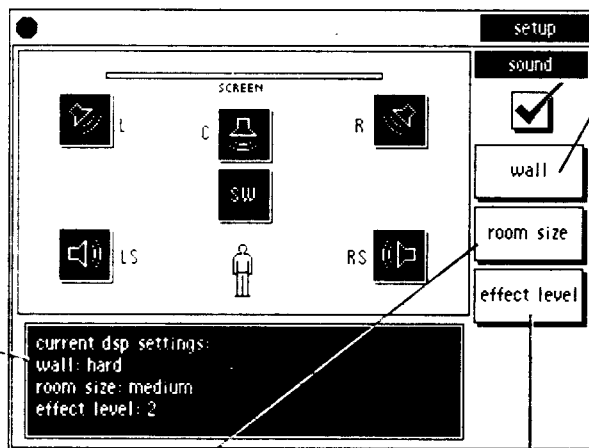

Changes the amount of DSP effect, or resets it to its default value.

Changes the amount of DSP effect, or resets it to its default value.

- 2 Touch the ROOM SIZE button. You can select from 3 different room sizes. The sizes refer to public spaces, so SMALL might be used to simulate a more intimate club, while LARGE could be used to simulate a large theater.
- 3 Touch the wall button. You can select from 3 different wall textures. SOFT makes the simulated walls absorb more sound (such as in a room full of people), while hard makes them reflect more sound (like a theater that's nearly empty).
- 4 Touch the EFFECT LEVEL button. You can change the effect level from 1 (very little effect) to 5 (maximum effect).
- 5 When you are done, touch the CHECK-MARK to return to the Setup screen.

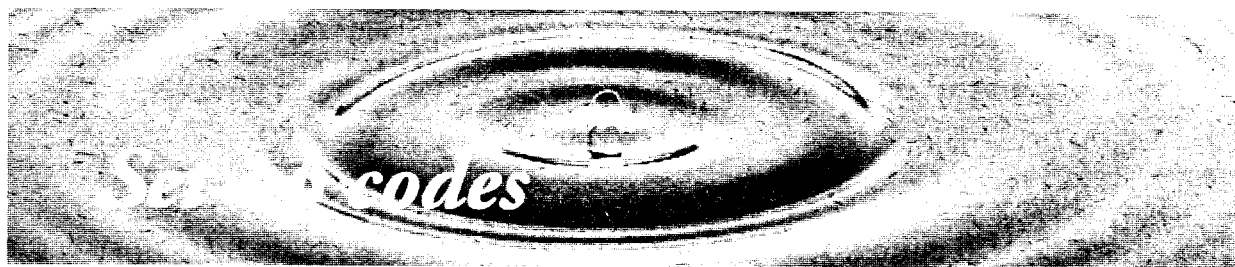

Use these codes with the instructions for setting up components, starting on page 49.

VCR

Maker	Set-up code		
Action	332	Fisher	062, 069, 081, 119
Admiral	063	Fuji	048, 050
Adventura	015	Funai	015
Aiko	293	Garrard	015
Aiwa	015	GE	050, 075, 080, 217
Akai	056, 064, 068, 076, 121, 171, 257	Go Video	247, 294
American High	050	GoldStar	033, 052, 053
Amstrad	340	Gradiente	015
Asha	255	Harley Davidson	015
Audiovox	052	Harman/Kardon	053, 090
Beaumark	255	Harwood	083, 087
Bell & Howell	119	Headquarter	061
Brandt	202	HI-Q	062
Broksonic	136, 199, 226, 310, 376	Hitachi	056, 057, 080, 097, 120, 160, 181, 250
Calix	052	Jensen	056
Canon	050, 182	JVC	023, 056, 082, 399
Capehart	035	KEC	052, 293
Carver	096, 161	Kenwood	053, 056, 082, 399
CCF	087, 293	KLH	087
Citizen	052, 293	Kodak	050, 052
Colt	087	Lloyd	015
Craig	052, 062, 087, 255, 286	Lloyd's	223
Curtis Mathes	050, 056, 075	Logik	087
Cybernex	066, 255	LXI	052
Daewoo	032, 035, 060, 102, 293	Magnavox	050, 054, 096, 118, 125, 164
Daytron	035	Magnin	255
Dynatech	015	Marantz	050, 096, 161
Electrohome	052	Marta	052
Electroponic	052	Matsushita	050, 177, 469
Emerex	047	MEI	050
Emerson	015, 017, 051, 052, 058, 076, 083, 103, 136, 199, 223, 224, 226, 227, 293, 309, 310, 376	Memorex	015, 050, 052, 054, 061, 062, 063, 119, 255, 283, 314
		MGA	058, 076
		MGN Technology	255
		Minolta	057, 120

Mitsubishi	058, 076, 082, 090, 188, 229, 257	Sanyo	061, 062, 119, 255, 283
Motorola	050, 063	Scott	058, 060, 136, 199, 225, 226, 227
MTC	015, 255	Sears	050, 052, 057, 061, 062, 069, 072, 081, 119, 120
Multitech	015, 087	Sharp	063, 077
NAD	073	Shintom	087
NEC	053, 055, 056, 065, 082, 097, 119	Shogun	066, 255
Nikko	052	Singer	087
Nikon	049, 268	Sony	026, 047, 048, 049, 050, 268
Noblex	255	STS	057
Olympus	050, 241	Sunpak	268
Optimus	052, 052, 063, 073, 119, 177, 447, 469	Sylvania	015, 050, 058, 096, 118, 125
Optonica	077	Symphonic	015
Orion	310	Tatung	056
Panasonic	050, 092, 177, 240, 241, 469	Teac	015, 056
Penney	050, 052, 053, 055, 057, 069, 255	Technics	050, 177
Pentax	057, 080, 120	Teknika	015, 050, 052, 067
Philco	050	Telefunken	202
Philips	050, 077, 096, 125	TMK	051, 223, 255
Pilot	052	Toshiba	058, 060, 072, 081, 225, 227
Pioneer	073, 082	Totevision	052, 255
Portland	035	Unitech	255
Profitronic	255	Universum	340
Protec	087	Vector	060
Pulsar	054, 066	Vector Research	053, 055
Quarter	061	Video Concepts	055, 060, 076
Quartz	061	Videosonic	255
Quasar	050, 092, 177, 469	Wards	015, 050, 057, 062, 063, 075, 077, 087, 096, 164, 227, 255
Radio Shack	015, 052	XR-1000	015, 050, 087
Radix	052	Yamaha	053
Randex	052	Zenith	048, 049, 054
RCA	057, 075, 080, 092, 120, 121, 164, 217		
Realistic	015, 050, 052, 061, 062, 063, 077, 081, 119		
Ricoh	049, 268		
Runco	054		
Saisho	160		
Salora	090		
Samsung	060, 066, 068, 255		
Sanky	054, 063		
Sansui	056, 082, 097, 286		

Laser disc players

Aiwa	218
Carver	079, 209, 338
Denon	187, 245, 256
Disco Vision	038
Funai	218
Hitachi	038
Kenwood	251, 273
Magnavox	209, 232, 256
Marantz	079, 209

Mitsubishi	074,
NAD	074
NEC	301
Panasonic	219,
Philips	079, 209
Pioneer	038, 074,
Quasar	219
RCA	143, 366,
Realistic	218
Samsung	338
Sega	038
Sharp	016
Sony	208, 216, 285,
Theta Digital	209
Yamaha	232

TV

A-Mark	018
Abex	047
Admiral	108
Adventura	061
Aiko	107
Akai	045, 113
Akura	233
Alaron	231
Alba	052, 233
Alleron	194, 198
Ambassador	192
Ampro	766
Anam	019, 024, 083, 195
Anam National	070
AOC	018, 034, 045, 067, 152, 200
Archer	018
Asuka	233
Audiosonic	052
Audiovox	018, 195
Basic Line	233
Baur	052
Belcor	034
Bell & Howell	031, 169
Beon	052
Blue Sky	233
Bradford	195

Brockwood	034
Broksonic	018
BTC	233
Bush	052, 233
Candle	045, 061, 071, 201
Carnivale	045
Carver	069, 185
Cathay	052
CCE	232
Celebrity	015
Centurion	052
Citizen	045, 054, 061, 071, 075, 107, 201, 295
Clairtone	200
Clarivox	052
Concerto	071
Contec	172, 173, 195, 200
Craig	195
Crown	052, 054, 195
Curtis Mathes	045, 054, 075, 169, 430
CXC	195
Cybertron	233
Daewoo	034, 052, 054, 106, 107, 466
Dainichi	233
Dansai	052
Daytron	034
Decca	052, 087
Dixi	052
Dumont	032, 034
Dwin	735, 789
Dynatech	064
Electroband	015, 200
Electrohome	396, 404, 424
Elin	052
Elite	233
Emerson	034, 053, 054, 169, 173, 192, 193, 194, 195, 196, 197, 198, 200, 251, 285, 295, 297, 478
Envision	045
Erres	052
Ferguson	052
Fidelity	097
Finlux	052, 087
Fisher	169, 174
Formenti	052

Fujitsu	087, 194	Liesenk & Tter	052
Funai	186, 194, 195	Logik	031
Futuretech	195	Luxman	071
GE	036, 042, 044, 062, 066, 070, 150, 189, 193, 297, 466	LXI	062, 069, 163, 169, 171, 193
GEC	052, 087	M Electronic	052
Genexxa	233	Magnavox	035, 039, 043, 045, 051, 069, 111, 201, 202, 245
Gibraltar	032, 034, 045	Majestic	030, 031
GoldStar	016, 017, 034, 045, 047, 052, 054, 071, 121, 193, 424	Marantz	045, 052, 069
Goodmans	052, 087	Mark	052
GPM	233	Matsui	052, 087
Granada	052, 087	Matsushita	265
Grunpy	194, 195	Mediator	052
Hallmark	193	Megatron	018, 160, 193
Hanseatic	052	MEI	200
Harman/Kardon	093	Memorex	031, 071, 121, 165, 169, 193
Harvard	083, 195	MGA	034, 045, 165, 170, 193
Hinari	052, 233	Midland	032, 047, 054, 062, 066, 150
Hitachi	047, 053, 071, 110, 112, 160, 166, 188, 242, 424	Minutz	036
Hypson	052	Mitsubishi	034, 108, 113, 165, 170, 193, 256
Indiana	052	Motorola	070, 108
Infinity	069	MTC	034, 045, 064, 071, 075, 106, 200, 231
Inno Hit	087	Multitech	064, 195, 232
Interfunk	052	NAD	171, 181, 193
Isukai	233	NEC	034, 045, 051, 071, 185, 512, 512
Janeil	061	Neckermann	052
JBL	069	NEI	052
JCB	015	Nikkai	052, 087, 233
Jensen	065	Nikko	045, 107, 193
JVC	051, 068, 197	Noshi	033
Kaisui	233	NTC	107
Kamp	231	Onwa	195
Kawasho	173, 231	Optimus	169, 181, 265
Kaypani	067	Optonica	108, 180
KEC	195	Orion	052, 251
Kendo	052	Osaki	087, 233
Kenwood	034, 045	Oso	233
Kloss	039, 061, 093	Osume	087
KMC	121	Otto Versand	052
Korpel	052	Panasonic	066, 070, 177, 265, 353
KTV	045, 054, 195, 198, 200, 232, 295	Penney	017, 018, 033, 034, 036, 042, 045, 047, 054, 062, 066, 075,
Leyco	052, 087		

	125, 150, 164, 171, 193	Sontec	052
Philco	034, 035, 043, 045, 069, 111	Sony	015, 026, 095, 126, 288, 368
Philips	052, 069	Soundesign	193, 194, 195, 201
Phonola	052	Soundwave	052
Pilot	034, 045, 054	Spectricon	018, 152
Pioneer	053, 181, 187	Squareview	186
Portland	034, 054, 107	SSS	034, 195
Prism	066	Standard	233
Proscan	062	Starlite	195
Protech	052	Supre-Macy	061
Proton	018, 046, 067, 193, 481	Supreme	015
Pulsar	032, 034	Susumu	233
Quasar	066, 070, 180, 234, 265	Sylvania	035, 043, 045, 069, 080, 111, 396
Quelle	052	Symphonic	186
R-Line	052	Sysline	052
Radio Shack	034, 045, 047, 054, 062, 071, 169, 180, 193, 195, 424	Tandy	087, 108, 233
Radiola	052	Tatung	018, 052, 064, 070, 087
RCA	033, 034, 044, 053, 062, 105, 150, 189, 293	Technics	066, 265
Realistic	034, 045, 047, 054, 071, 169, 180, 193, 195	Technol Ace	194
Revox	052	Techwood	018, 066, 071
Rhapsody	198, 200, 231	Teknika	031, 034, 054, 069, 071, 075, 107, 165, 194, 195, 201, 337
Roadstar	233	Tensai	233
Runco	032, 045, 512, 618	Tera	046
Sampo	045, 047, 054, 067, 115, 125	Texet	233
Samsung	034, 045, 047, 052, 054, 071, 075, 125, 193	Thorn	052, 087
Samsux	054	TMK	071, 192, 193
Sanyo	087, 161, 169, 174	Toshiba	051, 075, 164, 169, 171
SBR	052	Tosonic	200
Schneider	052, 233	Totevision	054
Scimitsu	034	Trical	172
Scotch	193	Ultra	406
Scott	034, 193, 194, 195, 251	Universal	042
Sears	030, 062, 069, 071, 161, 163, 164, 169, 171, 174, 183, 186, 193, 194	Universum	052
Sharp	054, 108, 168, 172, 180, 506	Vector Research	045
Shogun	034	Vestel	052
Siemens	052	Victor	068
Signature	031	Video Concepts	113
Simpson	201, 202	Vidikron	069, 257
Sonoko	052	Vidtech	034, 051, 193
		Viking	061
		Wards	031, 034, 035, 036, 042, 043, 044, 045, 069, 071, 095, 111,

	126, 180, 189, 193, 194
Watson	052
White Westinghouse	052
Yamaha	034, 045
Yoko	052
Zenith	031, 032
Zonda	018

Cable tuners

ABC	016, 018, 022, 023, 026, 028, 029, 032, 062
Allegro	168
Antronix	037, 222
Archer	037, 054, 168, 222
Belcor	071
Cable Star	071
Cabletenna	037
Cableview	037
Century	168
Citizen	168
Colour Voice	040, 046
Comband	247, 248
Comtronics	055, 075
Contec	034
Eastern	017
Electricord	093
Everquest	030, 055
Focus	415
Garrard	168
GC Electronics	071, 222
GE	247, 248
Gemini	030, 072, 085, 257
General Instrument	026, 291, 491
GoldStar	055, 159
Hamlin	024, 035, 049, 274, 288
Hitachi	026
Hytex	022
Jasco	168
Jerrold	018, 026, 027, 029, 030, 039, 062, 113, 291, 491
Linsay	455
Macom	048
Magnavox	042
Memorex	015

Movie Time	078, 093, 171, 218
Northcoast	329
NSC	078, 085, 171, 218
Oak	022, 034, 263
Panasonic	015, 036, 122
Panther	652
Paragon	015
Philips	040, 042, 043, 044, 045, 046, 168, 257, 305
Pioneer	038, 159, 275, 548
Popular Mechanics	415
Pulsar	015
Radio Shack	030
RCA	036
Realistic	222
Recoton	415
Regal	035, 274, 288, 294
Regency	017
Rembrandt	026, 085
RK	321
Runco	015
Samsung	055, 159
Scientific Atlanta	021, 023, 032, 292, 492
Seam	525
Signal	030, 055
Signature	026
SL Marx	055
Sprucer	036, 322
Standard Components	111, 170
Starcom	018, 030, 062, 113
Stargate	030, 055
Starquest	030
Sylvania	016
Tandy	273
Tatung	112
Teknika	161
TeleCaption	236
Teleview	055
Texscan	016, 111
Timeless	433
Tocom	027, 028, 074
Toshiba	015
Tusa	030
TV86	078
Uniden	240

Unika	037, 168, 222
United Artists	022
United Cable	018
Universal	037, 054, 071, 092, 093, 168, 206, 222, 337
Videoway	265
Vidtech	259
Viewstar	042, 075, 078, 126, 226, 273, 304
Zenith	015, 069, 540
Zentek	415

DSS

AlphaStar	772
Echostar	775
Hitachi	819
HTS	775
Hughes Network Systems	749
Jerrold	627
Panasonic	701
Primestar	627
RCA	566
Sony	639
Toshiba	790

Satellite

Amplica	087
Amway	058, 090
Astro Industries	110
Birdview	060, 094
BSR	110
Cable Innovations	569
Capetronic	110
Century	553
Channel Master	033, 227
Chaparral	068, 224
Citoh	179
Conifer	019
Connexions	411
Curtis Mathes	076, 087
DNT	411
Drake	033, 077, 079, 081, 164, 165,

	260
DX Antenna	056
Echostar	115, 163, 174, 185, 233, 284, 295, 327, 411, 469
Equus	196
Fuba	411
Fujitsu	201, 251
General Instrument	053, 065, 376, 569
Gould	070
Homecable	253
Hytek	110
Intersat	058
IQ	225
IQ Prism	225
Janeil	167
Jerrold	051, 376
Kenwood	279, 371
Legend	284
Macom	033, 065, 076
Memorex	284
NEC	117
Norsat	019
Panasonic	167
Philips	215
Pico	090
Primestar	376
Prosat	173
Radio Shack	569
Radix	411
Ramsey	090
Realistic	066, 067
Salora	197
Scientific Atlanta	249, 370
Seemann	411
Star Trak	195, 436, 562
Starcast	057
Strong	436
STS	056, 205, 225
SuperGuide	326
Toshiba	076, 097
Uniden	067, 089, 091, 253, 311, 385, 569
Wisi	411
Zenith	076, 079

CD players

ADC	033
Adcom	170, 249
ADS	258
Aiwa	027, 139, 172
Akai	171
Audio Alchemy	209
Audio-Technica	185
BSR	209, 260
California Audio Lab	044
Capetronic	252
Carrera	209, 409
Carver	172, 194
Craig	630
DAK	260
Denon	018, 049
DKK	015
Emerson	170, 179, 320, 484
Fisher	063, 103, 189, 194, 357
Garrard	260, 295, 408
GE	024, 349
Genexxa	047, 179, 320
GoldStar	398, 409, 432
Harman/Kardon	123, 188, 441
Hitachi	047, 170
Inkel	080
JVC	087, 670, 671, 673
Kenwood	043, 052, 063, 205, 352, 353, 354, 355, 538, , 873, 874
Kodak	302
Krell	172
Kyocera	033
Linn	172
Luxman	108, 164, 281, 498
LXI	320
Magnavox	144, 172, 320
Marantz	020, 044, 172, 195
McIntosh	302
MCS	044, 058
MGA	098
Mission	172
Mitsubishi	098, 113
NAD	034
Nakamichi	162
NEC	058, 249

Nikko	179, 185, 189
NSM	172
Onkyo	116, 117
Optimus	015, 047, 052, 063, 102, 111, 160, 190, 194, 209, 211, 295, 320, 357, 441, 483
Panasonic	044, 382, 767
Parasound	209
Philips	172, 289, 302
Pioneer	047, 111, 259, 320, 483
Proton	167, 172
QED	172
Quasar	044
RCA	024, 068, 170, 194, 320
Realistic	170, 179, 190, 194, 195, 252
Rotel	172
SAE	172
Sansui	172, 217, 320
Sanyo	102, 194, 364
Scott	170, 179, 320
Sears	320
Sharp	052, 195
Sherwood	080, 129, 195, 211, 441
Shure	058
Signature	123
Sony	015, 200, 505, 619, 620, 688, 742
Soundesign	160
STS	033
Symphonic	198
Teac	031, 060, 168, 189, 195, 198, 408
Technics	044, 318
Toshiba	034
Vector Research	209, 409, 432
Victor	087
Wards	123, 172
Yamaha	051, 185, 202
Yorx	476
Zenith	630

DVD

Mitsubishi	521
Panasonic	490

Pioneer	525
RCA	522
Sony	533
Toshiba	503

Cassette decks

ADC	186
Aiwa	044, 212, 215
Akai	203, 204, 298
Carver	044
Denon	091
Fisher	089
Garrard	323, 324, 454
Harman/Kardon	197
JVC	259, 288, 289
Kenwood	085, 086, 107, 198, 220, 248, 249, 266, 401
Kyocera	186
Luxman	106, 110
Magnavox	044
Marantz	024, 044
Memorex	116
Mitsubishi	298
NAD	159
Nakamichi	162
NEC	180
Onkyo	115, 151, 297
Optimus	042, 235, 352, 454
Panasonic	265
Philips	044
Pioneer	042, 114, 116, 235
Proton	043
RCA	041
Revox	205
Sansui	024, 044
Sharp	220
Sherwood	352
Sony	185, 258, 306
Teac	304, 323, 324
Technics	244
Victor	288, 289
Wards	042
Yamaha	109, 112, 220

Mini disc

Kenwood	841
Sony	505

NOTE: Although each setup code is designed to work with a number of different models, certain codes may not work with some models. Additionally, certain codes may only operate some of the functions available on a given model.



If not completely satisfied with this battery, call 1-800-551-2355 (9 am - 5 pm EST)
Duracell USA guarantees this battery against defects in material and workmanship.
Should any device be damaged by this battery due to such a defect, we will repair it at
our option if it is sent with the battery, postage prepaid to:

Duracell USA
Berkshire Park
Bethel CT 06801
Attn: Consumer Department

Duracell Inc
620 Newport Center Drive, Suite 540
Newport Beach, CA 92660
Tel: 800-331-3923
Fax: 714-720-0476